

# TRACK ROLLERS BEARING

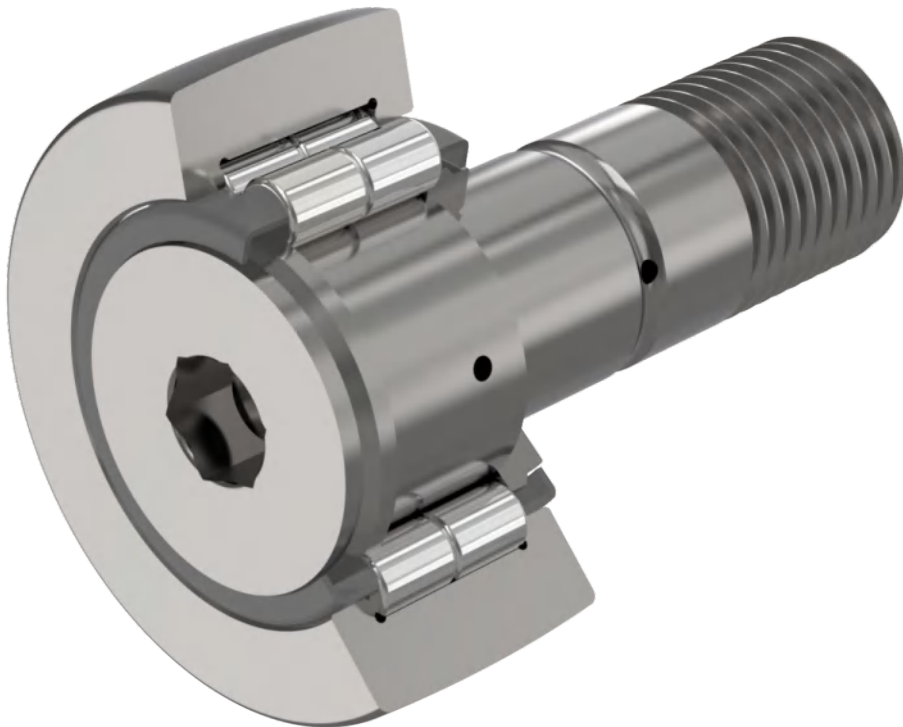

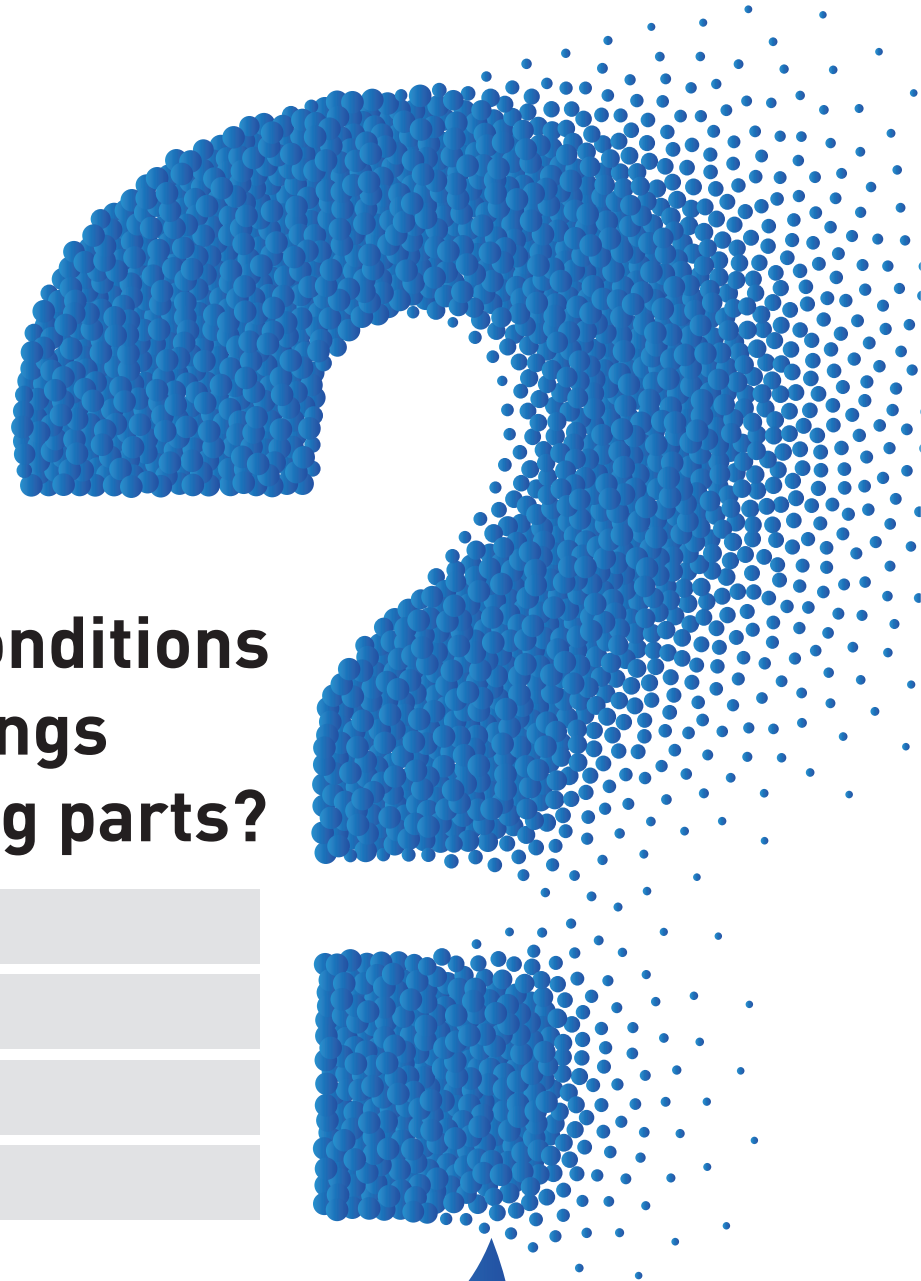

## Have you met any following conditions regarding bearings & its neighboring parts?

Heavy noise

Frequent failures

Overheating of operation

Shorter service life

**Do you want to find out the causes and  
get effective solutions?**

THB can help you do that.



THB's specialized  
technical services for  
various applications **include**

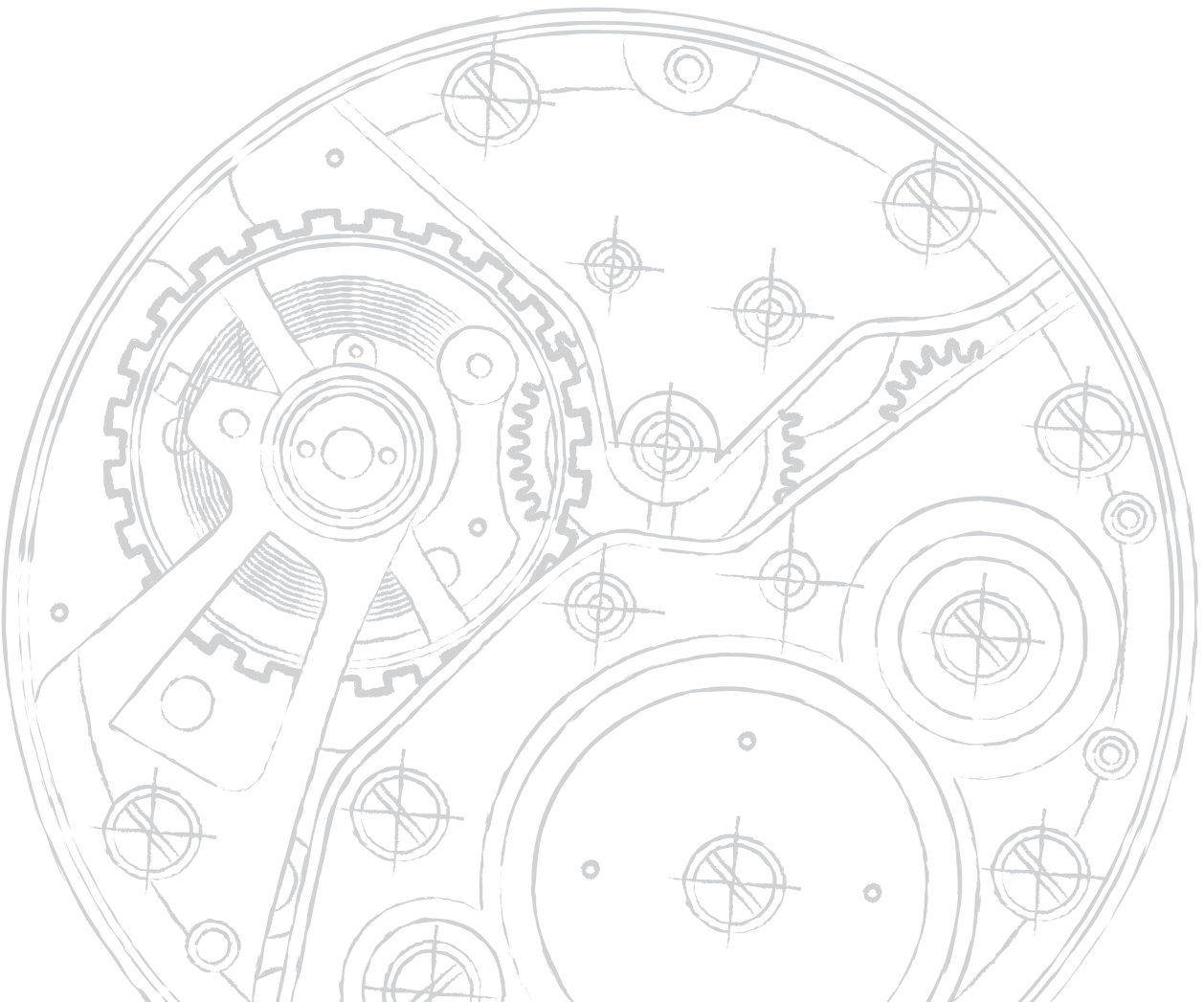



## DESIGN SELECTION

### Application analysis

To understand the difficulties in the transmission system; to prevent clients from potential problems in equipment design or operation.

### Product selection

To provide advices for selecting optimal bearing, in order to match clients' design requirements based on application characteristics.

### Application of special technologies

Depending on the application, special technologies (e.g., special coatings) will be selected to adapt to client's extreme working condition.

### Customizing bearing units products

To customize the complete mechanical unit, including bearings. Which can benefit both operation precision and assembly efficiency for clients.

### Optimization of design

Through analysis and optimization of the existing transmission design, enable the equipment to run faster at less energy consumption, as well as increasing reliability.

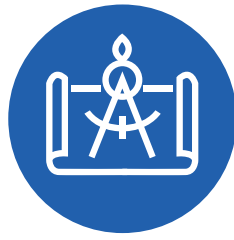

## STATUS ANALYSIS

### Performance Test

To use simulation software analysis and actual testing of the test machine to determine whether the bearings and its surrounding components could meet the requirements of the client (load, speed, temperature rise, noise and service life).

### Failure analysis

To analyze the materials, geometrical accuracy, surface damage and microstructure to identify the cause of any failure and then to provide an effective solution timely.

### Lubrication analysis and management

To analyze the equipment operation status and determine the lubrication management plan, including the selection of lubricants; lubricants application method and optimal lubrication cycle. Thus, it may help optimize the maintenance plan and improve the equipment efficiency.

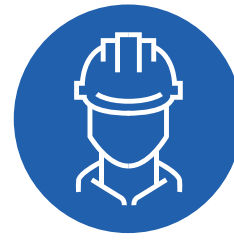

## AFTER SALES SERVICES

### Bearing application training

To provide clients with professional training in product selection, application technologies, installation and maintenance to help them improve their competitiveness.

### Industrial bearing remanufacturing

To provide diagnostic and effective remanufacturing services for heavy-duty, high-value products with long production cycles to extend bearing life and reduce costs.

### Maintenance solutions

Based on the characteristics of the industry and equipment operation, we can provide targeted maintenance and upgrade solutions to aid concern identification and improve equipment performance at an early stage.

# Who is THB



THB-  
a bearing technical service engineer at the R&D center who simulates the client's equipment conditions with professional design software to give professional bearing selection and design optimization advices.

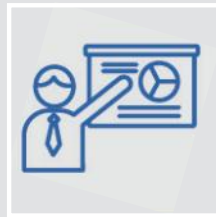

THB-  
a bearing application engineer with extensive experience in equipment manufacturing and operation sites, focusing on researching and solving bearing problems.



THB-  
a Chinese craftsman who provides clients with high quality products, focusing on bearing manufacturing processes and bearing quality control.



**THB is your technical advisor  
and business partner for various applications.**

## Overview

THB track rollers bearing is categorized into different types, including the yoke type track rollers, stud type track rollers, ball bearing track rollers, combined bearings and other specific roller bearings. Track rollers bearing has the thick-walled outer ring, which can not only withstand high radial loads, but also reduce deformation and bending stress. Such bearing is particularly suitable for use with cam drives and conveyor lines where the outer rings shall be rolled.

The outer ring surface of a THB track rollers bearing is typically configured as convex profile, which can reduce the shortening of bearing life due to the tilt of mounting surface and track to a certain extent, and can reduce the generation of track rollers bearing edge stress, thus benefiting the extended service life of the track rollers bearing and track.

THB, remaining committed to the customer first principle, endeavors to provide customers with the best product solutions. In addition to the standard rollers, we can also provide clients with coated long-life roller bearings, maintenance-free roller bearings with plastic state oil lubrication (including food-grade product) and anti-corrosion stainless steel track rollers bearing to meet the needs of our clients in different scenarios.



THB 

# Table of contents

---

	Page
Classification of THB Bearings	08
Model System	11
Product Description	15
Yoke Type Track Rollers	15
Stud Type Track Rollers	18
Ball Bearing Track Rollers	21
Design and Use	22
Parameter Sheet	40
Yoke Type Track Rollers	40
Stud Type Track Rollers	48
Ball Bearing Track Rollers	78
Combined Bearings	82

## Yoke Type Track Rollers

THB yoke type track rollers have thick outer rings with needle rollers or cylindrical rollers, which are mainly used in such applications as cam drives, bed guide rails, conveyors and linear guideway systems.

Yoke type track rollers can withstand high radial loads, and those with a convex crown profile on the outer surface generatrix can also withstand axial loads caused by minor misalignment defects, skewed running or short-term shocks.

Yoke type track rollers have structures with or without outer ring axial guides, or have structure with seals on both sides, or have an open structure. With an optimized convex crown profile on the outer surface of the outer ring, these bearings have a smaller Hertzian stress, conducive to reducing edge stress in tilted conditions, and reducing wear on the bearing track and extending the service life of the bearing tracks as well.

Yoke type track rollers are installed on shafts or bolts, which are available in types with or without inner rings.



## Stud Type Track Rollers

The stud type track roller is designed in the same way as the yoke type track roller with axial guide, in which the needle rollers or cylindrical rollers are used as its rolling element, and the inner ring is replaced with the supporting bolt. The bolt shaft has installation threads and both ends have inner hexagonal holes and re-lubrication circuit in the shaft. There are also rollers with tight-fitting eccentric locking collar. With the eccentric locking collar, the outer ring surface can be adjusted to achieve the most suitable contact with the adjacent structural supporting track.

Stud type track rollers of labyrinth seal type, gap type or contact seal type, etc. are available, which are sealed with metal, reinforced nylon, and nitrile rubber, etc.

The outer surface generatrix of the outer ring has a convex crown profile, which can withstand axial loads caused by minor misalignment defects, skewed running or short term shocks. When running on supporting tracks, the bearings have a smaller Hertzian stress, conducive to reducing edge stress in tilted conditions, and reducing wear on the bearing track and extending the service life of the bearing tracks as well.



## Ball Bearing Track Rollers

Ball bearing track rollers have the same design as deep groove ball bearings or angular contact ball bearings, but have thicker outer rings and convex coronal profile on the outer surface.

They can withstand high radial loads and bi-directional axial loads. Such bearings are properly enclosed.

Ball bearing track rollers with or without bolts are available.

Rollers without bolts shall be installed on shafts or bolts.



## Combined Bearings

THB combined bearings is a bearing unit consisting of an axial roller bearing and a radial roller bearing. Combined bearings characteristics small bearing, easy assembly by means of bolt welding and low comprehensive manufacturing costs.

Combined bearings are properly sized to sustain large radial and axial loads and the related parts are easy to replace.

THB's optimized internal structural design allows for uniform distribution of the mechanism's load-bearing capacity over the supporting track.

Such bearings are mainly used in various gantry lifting systems, conveyors and other applications.

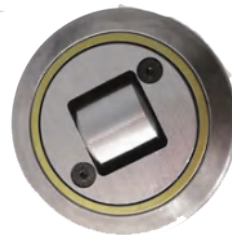

## Other Specific Track Rollers Bearing

### THB Stainless Steel Track Rollers Bearing

THB stainless steel track rollers bearing is made of high quality 440C or 420 stainless steel, in which the rolling element, outer ring and inner ring (shaft) are all made of stainless steel so that it can provide sufficiently high bearing load capacity and effectively prevent corrosion as well. Such bearings are mainly used in food, medical, special industries and other areas requiring adequate corrosion resistance.



## Other THB Specific Track Rollers Bearing

Heavy-duty stud type track rollers bearings with U-grooves

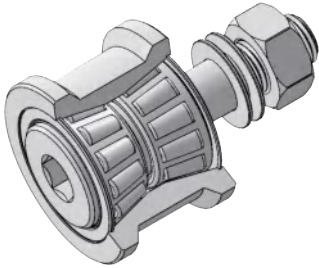

Heavy-duty track rollers bearing with U-grooves

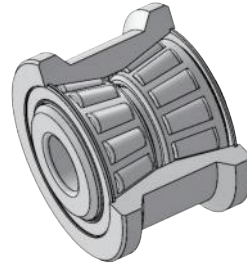

High-speed stud type track rollers bearings with V-grooves

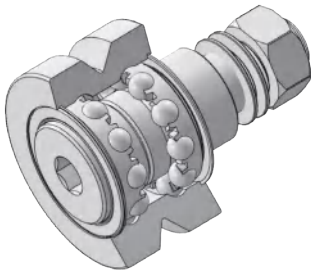

Track rollers bearing with R-grooves or two-point contact grooves

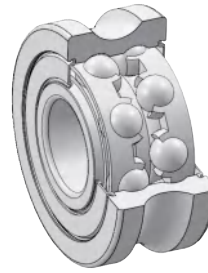

Combined stud type track rollers bearings with V-grooves

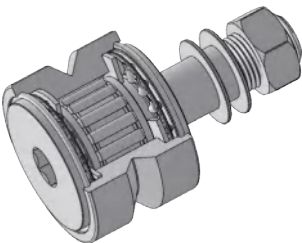

# Model system for THB track rollers bearing

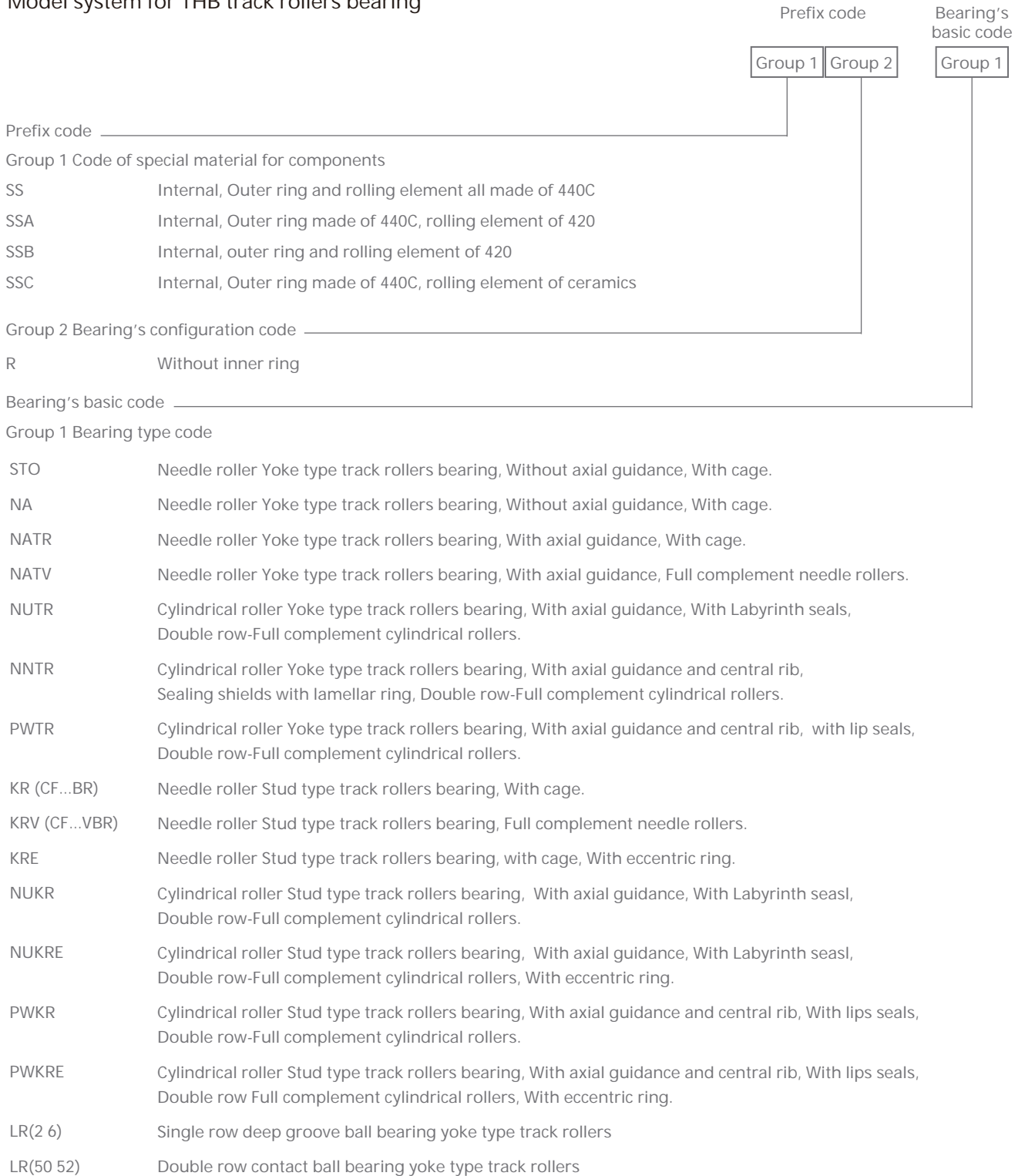

Bearing's basic model



Group 2 Bearing dimension series code \_\_\_\_\_  
 Yoke Type Track Rollers ID nominal dimension 3-digit representation,  
 nominal dimension (less than 3-digit) to be prefixed with zero

- NA 22 dimension series 22
- LR 2 internal dimension series, reference dimension series 02
- LR 6 internal dimension series, reference dimension series 10
- LR 50 internal dimension series, reference dimension series 30
- LR 52 internal dimension series

Group 3 Bearing dimension code \_\_\_\_\_

- STO ID nominal dimension in 2-digit or 3-digit, ID nominal dimension to be prefixed with zero
- NA Code to be designated in the same method as ascribed for the standard bearing series code
- NATR ID nominal dimension
- NATV ID nominal dimension
- NUTR ID nominal dimension, with the same ID and different OD, use the combination of ID+OD nominal dimensions
- PWTR ID nominal dimension, with the same ID and different OD, use the combination of ID+OD nominal dimensions
- NNTR Combination of IDxODxwidth nominal dimension

Stud type track rollers OD nominal dimension, with the same OD and different length, use the combination of OD nominal dimension+length nominal dimensions, with "-" in the between

LR Code to be designated in the same method as ascribed for the standard bearing series code

# Model system for THB track rollers bearing

Suffix code

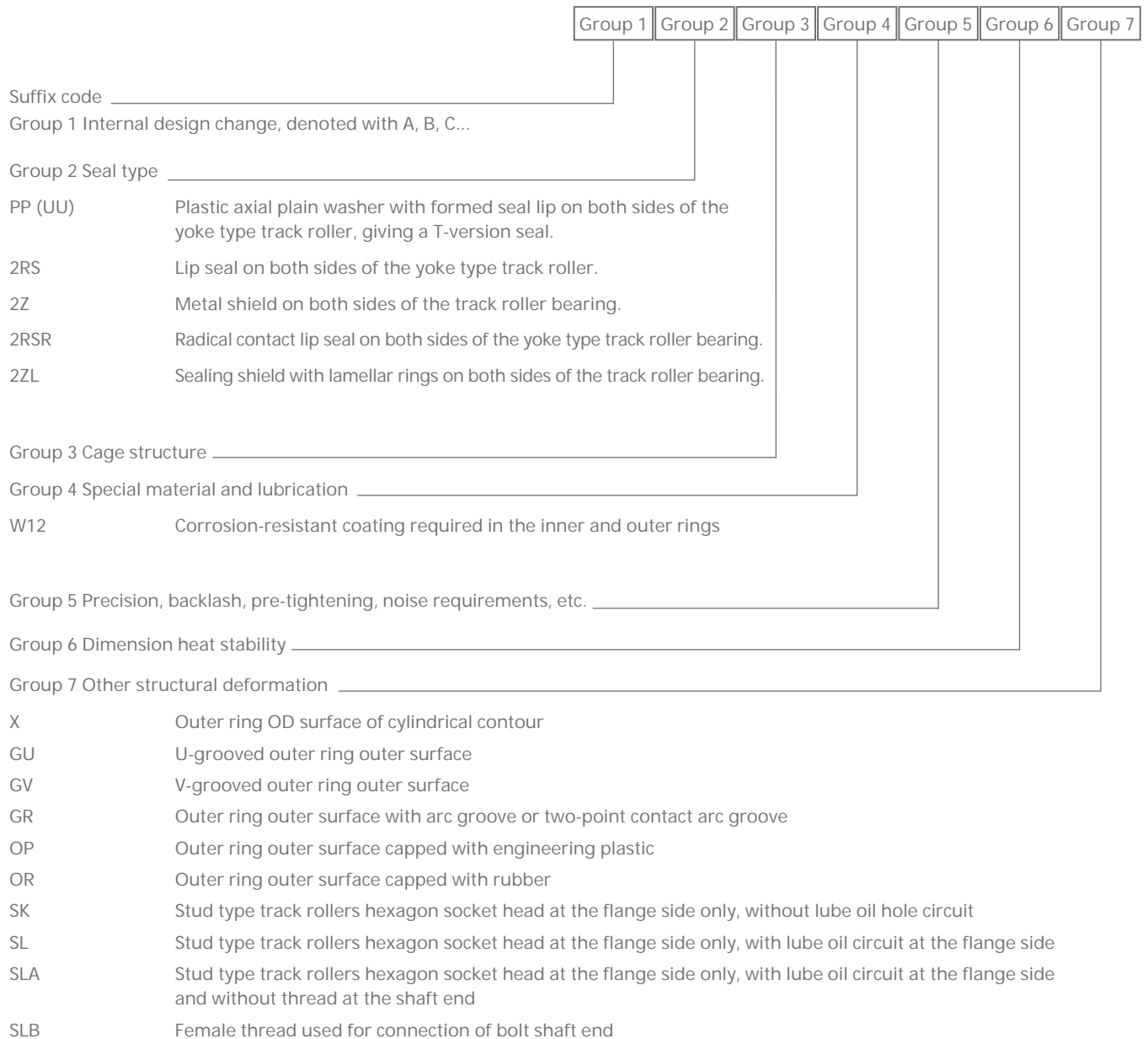

# Model system of THB roller bearing (CF inch series)

Bearing's basic model



## Product Description - Yoke Type Track Rollers

### Structural characteristics

Yoke type track rollers are single- or double-row bearing units mounted on a shaft or bolt. They consist of thick outer rings with a specific outer surface shape and needle roller-retainer assembly or full complement needle roller or full complement cylindrical roller assemblies. The outer ring has a crowned trimmed or cylindrical surface.

Yoke Type Track Rollers with crowned modified outer surface can withstand high radial loads and axial forces caused by slight misalignment and skewed operation. These bearings are suitable for applications such as cam drives, bed rails and conveyors, etc.

Yoke type track rollers with or without inner rings, or with seals on both sides, or with an open structure are available.

### Outer surface profile of outer ring

Yoke Type Track Rollers with a crowned modified outer surface are widely used to avoid edge stress caused by the inclination of the outer surface of the roller relative to the movement of the supporting track. The outer ring bearing (bearing suffix X) with cylindrical outer surface is also available as required by clients.

The outer surface curvature radius of yoke type track roller is generally  $R=500\text{mm}$ . For the outer surface curvature of roller NNTR series, please refer to the attached parameter sheet.

### Yoke Type Track Rollers without inner rings

The RSTO and RNA series of Yoke Type Track Rollers do not have inner rings. They are particularly compact, but the surfaces of the shafts or bolts used as raceway shall be hardened and ground.

The RSTO series are detachable. The outer ring, needle roller and cage assemblies, and inner ring can be installed independently.

For the RST and RNA series, the rollers are retainer guided. They do not have axial guidance function. The axial guidance of the outer ring as well as the needle roller and cage assembly must be provided by adjacent components. See Page 20 for details on the design of adjacent structures for track rollers bearing

RSTO



RNA

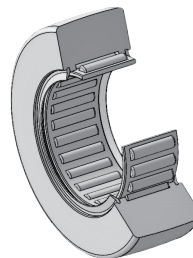

## Product Description - Yoke Type Track Rollers

Yoke type track rollers with inner rings

The roller STO and NA series are of the detachable structure. For STO series, the outer ring needle roller and cage assembly and inner ring can be installed separately. For NA series, the outer ring needle is an integral part of the cage assembly so that it may be separately assembled with the inner ring. STO, NA, NATR series have retainers.

The outer rings of STO and NA series do not have axial guidance function.

NATV series have full complement needle roller assembly and track rollers bearing. NUTR, PWTR and NNTR series have full complement cylindrical roller assembly.

NATR, NATV, NUTR, PWTR and NNTR series have axial guidance function, and can withstand certain axial forces.

Yoke type track rollers without retainers have as many rolling elements as possible to sustain high loads. Due to the increased internal frictional resistance, such yoke type track rollers can achieve speeds slightly lower than those of yoke type track rollers with retainer guidance.

STO

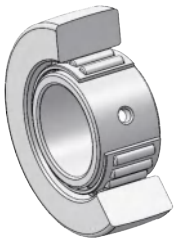

NA22..-2RSR

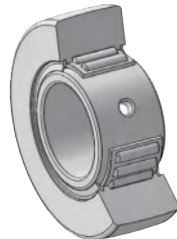

NATR..-PP

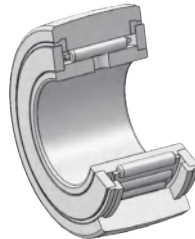

NATR

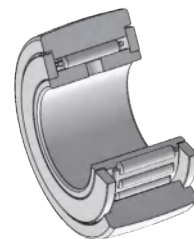

NATV..-PP



NATV

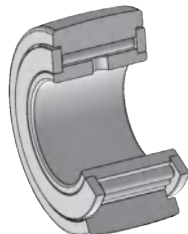

NUTR

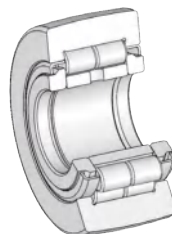

PWTR-2RS

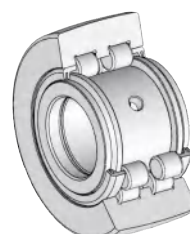

NNTR-2ZL

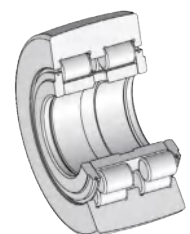

Sealing	Among the Yoke Type Track Rollers, except for the STO series in open structure without sealing, the other series have different sealing structures depending on the product series. See the parameter sheet for the sealing types.
Lubrication	Prior to delivery, the yoke type track rollers have been filled with lithium-based grease so that they can be re-lubricated through the inner ring or using equivalent grease. For special lubrication materials, please contact THB technical department.
Working temperature	The yoke type track rollers can operate at temperature of -30 °C to +140 °C. For the bearings with seals (suffix 2RS and 2RSR) and nylon retainers (suffix TV), the working temperature is within -30°C to +120 °C. Due to restriction on the selected grease and seal materials, NATR... -PP and NATV... -PP are suitable for use under the working temperature of -30 °C to +100 °C. If you need special products beyond the standard working temperature, please contact THB technical department.

## Product Description - Stud Type Track Rollers

### Structural characteristics

The stud type track rollers are similar to the yoke type track rollers in structure, and the inner raceway is replaced with the support bolt with fixed thread and lubrication hole. Given the specific surface shape and the thickened outer ring, stud type track rollers can bear high radial load as well as axial force generated by slight misalignment and skewed movement. The stud type track rollers are available in various designs with or without eccentric bushing. Such bearings are particularly suitable for applications such as cam drives, bed guides and conveyors.

The basic rating life of the PWKR series has been significantly improved as a result of the improved materials and optimized raceway shape. The static and dynamic load carrying capacity has also been improved. The optimized profile and improve surface quality of the rollers have reduced the stress of the rollers and rails supporting the track, realizing the solid bearing configuration and long service life.

### Outer surface profile of outer ring

Stud type track rollers with a crowned modified outer surface are widely used to avoid edge stresses caused by the inclination of the outer surface of the roller relative to the movement of the supporting track.

The curvature radius of the KR series is  $R=500\text{mm}$ .

The other series products have the outer ring profile derived from K1S optimization.

The stud type track rollers with such curvature profile shape have the following features:

1. Low Hertzian stress
2. Low edge stress during inclined operation
3. Small wearing of the support track
4. Extended service life of the support track
5. Stud type track rollers with or without eccentric locking collar available

### Stud type track rollers with retainers

KR and KRE series have needle roller retainer assemblies, and higher limit rotation speed. The KRE series have tight fitting eccentric locking collar at the shaft neck to facilitate the adjustment of position relative to the mechanism track.

KR

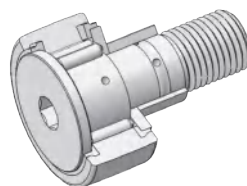

KRE..-PP

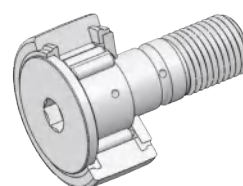

Stud type track rollers with full complement needle rollers or cylindrical rollers

KRV series bearings are available in full complement needle rollers and NUKR and PWKR series are available in full complement cylindrical rollers. The retainer-free bolt roller fully filled with roller needles or cylindrical rollers is highly loaded due to accommodation of more rolling elements. However, due to the increased frictional resistance, the limit speed of these bearings is slightly lower than that of stud type track rollers with retainer guidance.

The NUKRE and PWKRE series have tight fitting eccentric locking collar at the shaft neck to facilitate the adjustment of position relative to the track.

Axial guidance method

For KR and KRV series, the axial guidance of rollers is realized using contact retaining edges and contact washers. The axial guidance of NUKR and PWKR series is realized through rolling elements and ribs.

Stud-type track rollers with eccentric locking collars

The rollers with eccentric locking collars can be adjusted by means of hexagonal holes on the flange side or on the threaded end. It is possible to adjust the relative position of the outer contour surface of the outer ring and the support raceway, which also allows the appropriate reduction of manufacturing accuracy of the adjacent structure. When multiple stud type track rollers are used simultaneously, load distribution can also be improved, making it easy to implement a linear guidance system with pre-load.

The position of the highest point of the eccentric locking collar is marked on the end face of the bolt and the eccentric distance  $e$  is indicated in the dimension table. This is also the location of the radial re-lubrication hole, which should be located in the non-load area of the rolling contact. The eccentric locking collar covers the radial lubrication hole in the bolt. Therefore, re-lubrication must be carried out through the end face.

KRV

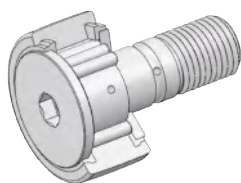

NUKR

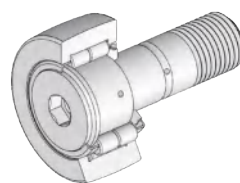

PWKR

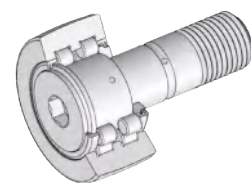

NUKRE

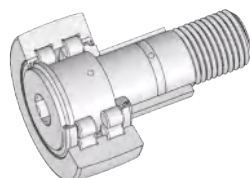

PWKRE

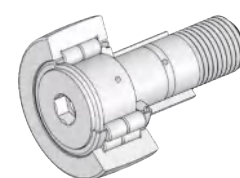

## Product Description - Stud Type Track Rollers

Sealing	Stud type track rollers are sealed on both sides. Different sealing structures can be provided according to the different configurations of the product series. See the parameter sheet for the sealing types.
Lubrication	At the factory, the stud type track rollers bearings are filled with lithium-based grease and can be re-lubricated through the specific bolt shaft oil hole using equivalent grease. For special lubrication materials, please contact THB technical department.
Working temperature	<p>The working temperature of the track rollers bearing is -30°C to +140°C. For the bearings with seals (suffix 2RS), the working temperature is from -30°C to +120°C.</p> <p>Due to restriction on the grease and seal materials, the stud type track rollers KR, KRV and KRE series are suitable for the working temperature of -30°C to +100°C.</p>

## Product Description - Ball bearing track rollers

**Structural characteristics** Ball bearing track rollers are non-separable, single-row or double-row ball bearings with thick outer rings. In addition to withstanding very high radial loads, these bearings can also withstand axial forces in both directions. The outer ring has a crowned trimmed or cylindrical surface. The crowned and modified outer surface is designed for applications where the rollers are inclined relative to the support track and edge stresses must be avoided. Ball bearing track rollers are available with inner rings, support bolts and plastic cover on the outer ring.

**Outer surface profile of outer ring** The curvature radius of the ball bearing track rollers and stud type track rollers with crowned and modified profile surface is  $R=500\text{mm}$ . The suffix of track rollers bearing with cylindrical outer surface is X.

**Ball bearing track rollers** Ball bearing track rollers consist of outer rings with a crowned and modified or cylindrical outer surfaces, inner rings, balls and nylon retainer assemblies. They are similar to the deep groove ball bearings and angular contact ball bearings in structure, and may be installed on shafts or bolts. LR6, LR60 and LR2 support type ball bearing rollers are single row units and LR50, LR52 and LR53 are double row units.

LR6, LR60, LR2



LR50, LR52, LR53

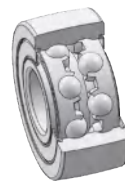

**Sealing** Ball bearing track rollers are sealed on both sides. Different sealing structures can be provided according to the different configurations of the product series. See the parameter sheet for the sealing types.

**Lubrication** THB Ball bearing track rollers are filled with lithium-based grease at factory. In some cases, double-row ball rollers can also be re-lubricated through lubricating holes in the inner bore surface. For special lubrication materials, please contact THB technical department.

**Working temperature** Due to restrictions on the grease, retainer materials and seal materials, ball bearing track rollers are suitable for the working temperature of  $-20^{\circ}\text{C}$  to  $+120^{\circ}\text{C}$ .

## Design and Use

### Yoke type track rollers, stud type track rollers

Principle of selecting yoke type track rollers and stud type track rollers

Both yoke type track rollers and stud type track rollers have thick outer rings to withstand the higher radial loads. If these rollers are used to support tracks in a plane, since the outer ring is subject to rotation and force during the movement, the rollers will be subject to certain elastic deformation. Compared to rolling bearings mounted in the block bore, rollers have the following characteristics:

1. Based on the working characteristics of track rollers bearings with rotating outer rings, the modified effective basic rated loads  $C_{r,w}$  and  $C_{0r,w}$  are used, and they are the determining factors to be considered in calculating the roller service life.
2. Refer to the bending stress of the outer ring. The permissible radial load  $F_{r,per}$  (dynamic) and  $F_{0r,per}$  (static) bending stress of the track rollers bearing is not allowed to exceed the permitted strength of the material.

Permissible radial load under dynamic loading

For track rollers bearings with rotating outer rings subject to dynamic loads, the effective dynamic load rating  $C_{r,w}$  is used to calculate the basic rating life. The radial dynamic load shall not exceed the permissible radial dynamic load  $F_{r,per}$ . If  $F_{r,per}$  is not provided, use the effective rated dynamic load  $C_{r,w}$  instead. If the effective rated static load  $C_{0r,w}$  is lower than the effective rated dynamic load  $C_{r,w}$ ,  $C_{0r,w}$  shall be used instead.

Permissible radial load under static loading

For track rollers bearings that are stationary or have only little rotational movement, it is equivalent to the track rollers bearings subject to static loads, and the effective static load rating  $C_{0r,w}$  shall be used to calculate the static load safety factor  $S_0$ . It is not allowed to exceed the permissible radial static load  $F_{0r,per}$ . If  $F_{0r,per}$  is not provided, the effective rated static load  $C_{0r,w}$  shall be used instead. The radial load acting on the bearing shall not exceed this value. In addition to the permissible radial static load, the permissible radial load of the supporting rail must also be considered.

Load-bearing capacity and life cycle

The methods of calculating rating life are as follows:  
Calculation of basic rating life according to DIN ISO 281  
Calculation of corrected rating life according to DIN ISO 281  
Use of the expanded calculation method for corrected reference service life in accordance with DIN ISO 281-4  
Please contact THB technical department if needed.  
For yoke type track rollers, stud type track rollers and ball bearing track rollers, the following values must be replaced:  
 $C_r, C_{0r} = C_{r,w}, C_{0r,w}$   
Effective rated dynamic load or static load  
 $C_{ur} = C_{ur,w}$   
Please refer to the fatigue limit load of the rollers in the dimension table.

Other formulas for calculating the basic rating service life

$$L_s = 0.0314 \cdot D \cdot \left( \frac{C_{rw}}{P_r} \right)^p$$

or

$$L_h = 26.18 \cdot \frac{D}{H \cdot n_{osc}} \cdot \left( \frac{C_{rw}}{P_r} \right)^p$$

or

$$L_h = 52.36 \cdot \frac{D}{v} \cdot \left( \frac{C_{rw}}{P_r} \right)^p$$

$L_s$   $10^5$  m

basic rating life,  $10^5$  m

$L_h$  h

basic rating life, unit: hours

$C_{rw}$  N

$C_{rw}$  N

$C_{rw}$  is the load of constant intensity and direction, under which a set of sufficient identical track rollers bearings can achieve a basic rating life per one million revolutions.

$P_r$  N

Equivalent dynamic load (radial load)

P-life index:

$P = 3$ , for support and stud type track rollers with ball rolling elements.

$P = 10/3$ , for support and stud type track rollers with needle rollers or cylindrical rollers

$n$  min<sup>-1</sup> running speed

$D$  mm

Roller outer diameter

$H$  m

Individual stroke for reciprocating motion

nose min<sup>-1</sup>

Number of reciprocations per minute

$v$  m/min Average running speed.

## Design and Use

### Yoke type track rollers and stud type track rollers

#### Service life

Service life is the actual life of the roller bearing. It is calculated in a way much different from that of the basic rating life.

This is due to the wearing or fatigue caused by the following factors:

1. The working conditions are different from those under which the rating life is calculated
2. The roller is out of alignment with respect to the support track during operation
3. Working clearance is too small or too large
4. Rollers are contaminated
5. Inadequate lubrication
6. The working temperature is too high
7. The bearing oscillates at a very small angle, resulting in Pseudo Brinell indentation
8. Wearing between the outer surface of the outer ring and the support track
9. Serious vibrations and Pseudo Brinell indentation
10. Shock load is extremely large and the static load is too large
11. Early damage to roller parts caused by improper installation.

Due to the diversity of installation and working conditions, it is impossible to determine the service life precisely in advance.

The most reliable method is to obtain a life estimate that is close to the actual life by comparing with working conditions in similar applications.

#### Static load safety factor

The static load safety factor  $S_0$  is a safety assessment criterion for bearings to avoid permanent deformation:

$$S_0 = \frac{C_{0rw}}{F_{0r}}$$

$S_0$	–
Static load safety factor	
$C_{0rw}$	N
Effective rated static loads, See dimension table	
$F_{0r}$	N
Maximum radial static load on rollers	

When the static load safety factor  $S_0 < 8$ , the roller is considered to be subject to a high load.

When the static load safety factor  $S_0 < 1$ , plastic deformation of the roller and raceway will be caused, which will compromise the operation stability.

This case is only allowed for bearings in applications where there is only little rotational movement or where the bearings are less important.

If the static load safety factor  $S_0 < 2$ , please contact THB technical department.

Minimum load

To ensure that the normal rotation of the outer ring of the track rollers bearing without sliding, or to prevent the roller from running out of the support track during operation, the roller must be subject to a minimum load in its dynamic operation. In general,  $C_{0rw}/F_r < 60$  is used to calculate the minimum load.

Skew movement

The skew movement will generate additional axial force on the bearing and cause axial sliding at the rolling contact between the outer ring and the support track. Whether wear occurs depends on the skew angle and the lubrication state of the friction area.

Text on image: The adhesion friction between the outer ring and the track is completely lost, accompanied by severe wearing. When the skew angle  $\alpha \geq 1.4 \cdot 10^{-4} \cdot pH(^{\circ})$  or  $\alpha \geq 2.5 \cdot 10^{-3} \cdot pH$  (mrad), the adhesive friction between the outer ring and the track is completely lost, resulting in severe wearing.

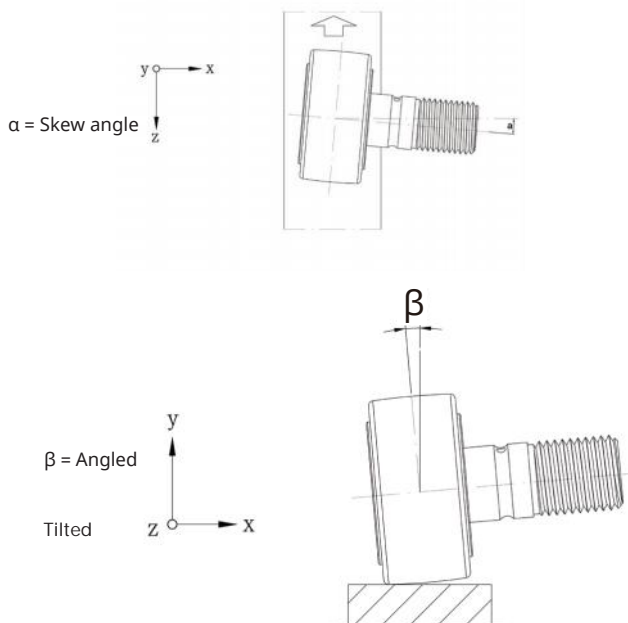

If tilting occurs during motion, there will be an increase in edge stress, especially for rollers with cylindrical outer rings. Rollers with a crowned modified outer rings are less sensitive to tilting, which should be preferably used. It has been proved that cylindrical outer ring  $\beta > 0.1^{\circ}$  (1.7mrad) and crowned outer ring  $\beta > 0.25^{\circ}$  (4.4mrad) is prone to damage.

Rotation speed

The permissible maximum speed of a track rollers bearing is mainly determined by its working temperature. The working temperature depends on factors such as the bearing type, load, lubrication conditions and cooling conditions, etc..

Rotation speed during continuous operation

The speed  $n_{DG}$  in the dimension table is used for reference. They are determined by the following conditions: Grease lubrication  
 Load for continuous operation  $< 0.05 \cdot C_{0rw}$   
 Skew movement angle  $\alpha < 0.03^{\circ}$  ( $< 0.5$  mrad)  
 Ambient temperature  $+20^{\circ}C$   
 Outer ring temperature  $+70^{\circ}C$   
 Lubricated support track and bearing outer profile surface are free of external axial loads.  
 Under the following working conditions, the rotation speed must be reduced:  
 Load  $> 0.05 \cdot C_{0rw}$   
 Poor heat dissipation caused by additional axial load (skew movement)  
 Higher speed can be achieved with intermittent operation and pulse oil lubrication.

## Design and Use

### Yoke type track rollers and stud type track rollers

Rotation speed of track rollers bearing with contact seals

The speed of a track rollers bearing with contact seal is also limited by the permissible sliding speed of the seal lip.

Friction torque

The friction torque  $M_R$  of a track rollers bearing depends on many factors, such as load, speed and roller type, as well as lubrication and seal friction. Due to the wide range of these factors, the simulated calculation of the friction torque is only for reference. For rollers without contact seals, the following formula is used to calculate the friction torque under normal working conditions and at medium speed:

$$M_R = f \cdot F_r \cdot \frac{d_M}{2}$$

$M_R$  Nmm  
Friction torque of the track rollers bearing

$f$  –  
friction torque coefficient, see the following table

$F_r$  N  
Radial load

$d_M$  mm  
Average diameter of the roller bearing

The values of the friction torque coefficient  $f$  in the table are suitable for track rollers bearing without seals subject to radial loads.

Higher values will be required for track rollers bearing with seals. Given additional axial loads caused by, for example, large skew, significant increase in these values is expected, especially for needle rollers. Ball bearing track rollers can withstand a certain axial force with the friction torque not significantly varied.

Friction coefficient  $f$

Track rollers type	Coefficient $f$
Ball bearings, single-row	0.0015 to 0.002
Ball bearings, double-row	0.002 to 0.003
Cylindrical roller bearings, fully loaded	0.002 to 0.003
Needle roller bearings with retainers	0.003 to 0.004
Needle roller bearings, fully loaded	0.005 to 0.007

Resistance to movement

When a track rollers bearing rolls on track, it must overcome not only the friction inside the bearing, but also the friction between the outer ring and the track.

The resistance to movement,  $F_v$ , is determined by the following equation:

$$F_v = \frac{2 \cdot (f_R \cdot F_r + M_R)}{D}$$

$F_v$  N  
Resistance to movement

$f_R$  mm  
Rolling friction data for hardened steel support track:  
 $f_R = 0.05$  mm

$F_r$  N  
Radial load

$M_R$  Nmm  
Friction torque of track rollers bearing

$D$  mm  
Roller outer diameter

Two contact areas in the track rollers bearing

The two contact areas in the track rollers bearing must be lubricated separately for:  
1. Rolling elements and raceway  
2. The outer surface of the track rollers bearing and the support track.

Lubrication of bearings

For the yoke type track rollers and stud type track rollers based on needle rollers and cylindrical rollers, lithium-based soap complex mineral oil grease with EP additives shall be used.

Recommended grease for re-lubrication

Arcanol grease	Designation to DIN 51825	Type of grease	Tack roller
LOAD150	KP2N-20	Lithium soap grease with mineral oil base	Yoke and stud type track rollers based on rollers
LOAD220	KP2N-20	Lithium-calcium soap grease with mineral oil base	Yoke and stud type track rollers based on rollers
MULTI3	KP3K-30	Lithium soap grease with mineral oil base	Yoke and stud type track rollers based on balls

Lubrication of track rollers bearing

For the yoke type track rollers and stud type track rollers based on needle rollers and cylindrical rollers, lithium-based soap complex mineral oil grease with EP additives shall be used.

If the contact area cannot be lubricated, wear is bound to occur, especially under heavy-duty and high-speed working conditions.

Oil lubrication

For oil lubrication, it is recommended to use CLP type lubricants according to DIN 51517.

Grease lubrication

For grease lubrication, lithium soap-based greases according to DIN 51825 should be used. The re-lubrication interval shall be determined based on working conditions. Re-lubrication must be carried out at least when frictional corrosion first appears, which can be identified by the appearance of red color at the support track or outer ring.

## Design and Use

### Yoke type track rollers and stud type track rollers

#### Centralized lubrication of stud type track rollers

For stud type track rollers, if the centralized lubrication system is used, the lubrication joint and the standard bolt with hexagonal holes at both ends of the stud type track rollers shall be used for connection (as illustrated below). It has a hexagonal head adapter and a quick connect fitting.

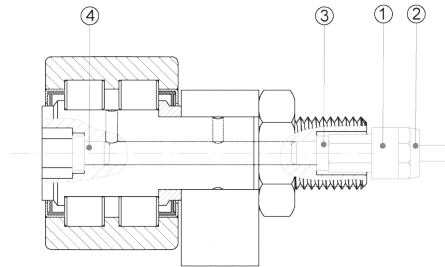

#### Re-lubrication intervals for re-lubrication interval calculation

The stud type track rollers must be re-lubricated periodically during its operation at the re-lubrication interval (refer to the following table).

Load ratio $C_{Orw}/P_r$	Maximum working speed $n_{max}$ , $n_{DG}$ percentage			
	10	25	50	
$5 > C_{Orw}/P_r \geq 3$	0.5 year	-	-	-
$10 > C_{Orw}/P_r \geq 5$	Every year	4 months	Every month	-
$C_{Orw}/P_r \geq 10$	Every year	8 months	2 months	14 days

The unused lubrication holes of stud type track rollers must be closed with the funnel-shaped grease nipples or plugs provided.

#### Adjacent structure of yoke type track rollers

For yoke type track rollers without inner rings, the track surface on the shaft or bolt must be hardened and ground (see the table below for specific requirements). The surface hardness of 670 HV + 170 HV must be assured, providing sufficient hardening depth CHD or SHD.

#### Tolerances and surface quality of shaft or bolt tracks

Diameter tolerance of shaft or bolt		Roughness	Roundness	Parallelism
Without inner ring	With inner ring	max.	max.	max.
k5	g6 (point load)	Ra0.4 (Rz2)	25% of the diameter tolerance	50% of the diameter tolerance

Positioning of yoke type track rollers without axial guidance

For yoke type track rollers without axial guidance, the outer ring and the needle roller and cage assembly must have lateral guidance (as illustrated below).

The surfaces in axial contact with the outer ring must be properly machined (Ra2 recommended), which shall be wear-resistant and lubricated.

The yoke type track rollers without axial guidance are separable.

The outer ring shall match with the needle roller and cage assembly, and must not be interchanged with other bearing parts of the same size during installation.

The tolerance of the inner circle of the roller mating with the inner ring is F6, and can be interchanged within the same accuracy class.

RSTO type

As shown in the figure: lateral guidance of the outer ring and needle roller and cage assembly

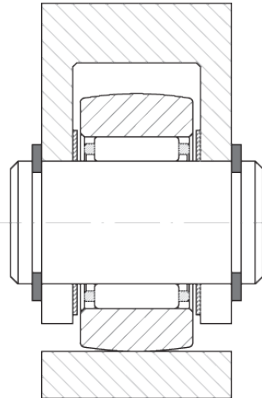

## Design and Use

### Yoke type track rollers and stud type track rollers

Positioning of yoke type track rollers bearing with axial guidance

Yoke type track rollers with axial guidance must be axially clamped in position. If there is an axial load, the axial washer must be adequately supported axially. The values of dimension  $d_2$  in the dimension table must be strictly followed. Yoke type track rollers NATR and NATV can be positioned with conventional fasteners such as snap rings.

NATR

① Snap ring

$d_2$ =adjacent structure diameter

As shown in the figure

Using snap ring for positioning

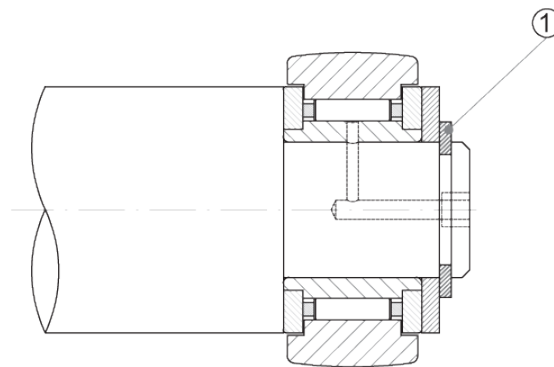

PWTR...-2RS

As shown in the figure

Clamping of inner ring

and axial washer

For NNTR... -2ZL, NUTR, PWTR... -2RS, the inner ring and axial washer must be axially located.

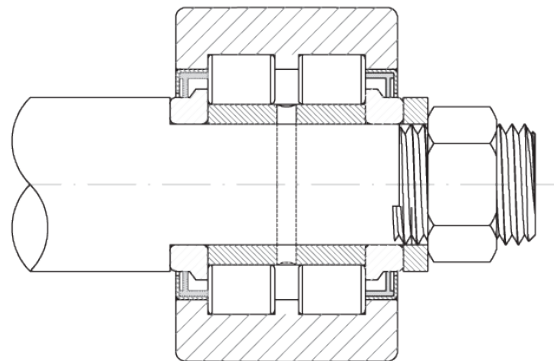

Adjacent structure of stud type track rollers

Since the tolerance of the bolt shaft without eccentric locking collar is  $h7$  and the tolerance of the bolt shaft with eccentric locking collar is  $h9$ , the fit with the hole of tolerance  $H7$  is a clearance fit.

The positioning surface of the stud type track rollers must be flat, vertical and of sufficiently tall. The strength of the nut positioning surface must be high enough. The dimension shall not be smaller than  $d_2$  in the dimension table.

The entrance end of the positioning hole should not be chamfered by more than  $0.5 \times 45^\circ$ .

#### Axial location

Hexagonal nuts must be used to axially fasten the stud type track rollers. In case of severe vibration, the stud type track rollers shall be positioned using self-locking nuts or special locking washers according to DIN 985.

For self-locking nuts, high locking torque is required and the nut manufacturer's recommendations must be observed.

#### Positions of lubrication holes

The position of the radial lubrication hole is at the flange end of the bolt, which must not be in the load area.

#### NUKR

##### ① Mark

As shown in the figure

Positions of lubrication holes

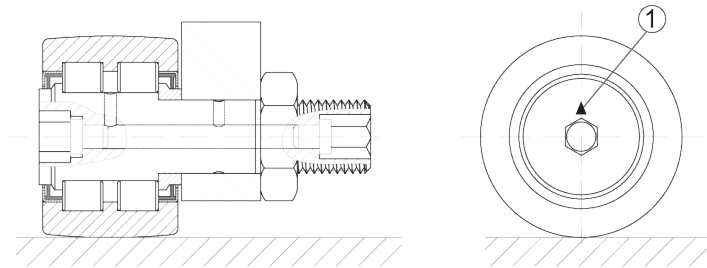

#### Protection of the support track

! The support track should be protected from contamination. If necessary, a protective cover or a wiper preferably made of felt should be placed in front of the rollers.

##### ① Dust cover

As shown in the figure

Protection of the support track from contamination

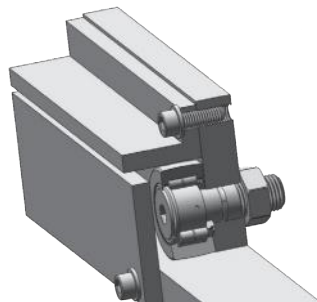

#### Installation

Track rollers bearing are precision mechanical components. These products must be properly handled before and during installation. Trouble-free operation can be assured should installation be conducted properly.

The product must be protected from dust, contaminants and moisture. Contaminants can impair the operating performance and working life of bearings.

Do not overcool the bearings. Moisture from condensation can lead to corrosion of bearing and its blocks. The yoke type track rollers RSTO and STO are detachable. The outer ring shall match with the needle roller and cage assembly, and must not be interchanged with other bearing parts of the same size during installation.

The installation area must be kept clean without any dust. Check the dimensional and geometric accuracy and cleanliness of the mating surfaces.

The bearing block surface shall be coated with a little lubricant or rubbed with solid lubricant.

The bearing must be filled with lubricant after installation. Finally, check if bearings are correctly assembled for normal operation.

## Design and Use

### Installation tools

Depending on applications, the following tools can be used for installation:

1. Induction heaters;
2. Heating box; heating temperature to +80°C
3. Mechanical or hydraulic devices; using a mounting sleeve covering the entire circumference of the bearing collar end face
4. Hammer and mounting sleeve; hammer on the entire annular surface of the mounting sleeve

The mounting force shall not be transferred through the rollers. Direct hammering on the bearing rings must be avoided.

To ensure the seals are not damaged during installation. For stud type track rollers bearings, the flange surface should not be hammered directly. Instead, a special installation tool that can cover the entire flange surface should be used.

### Disassembly guide

Due consideration shall be given to bearing disassembly at the preliminary design of bearing arrangement. If bearings will be used again:

1. Do not directly hit on the bearing rings
2. Do not transfer the disassembly force through the rolling elements
3. Clean the bearings thoroughly after disassembly

### Installation and disassembly of track rollers bearing (needle rollers and cylindrical rollers)

If the tolerance is not favorable for installation, press-fit equipment should be used to press the track rollers bearing onto the shaft or stud. When installing the inner ring, care should be taken that the press-fit force is evenly distributed on the end face of the inner ring.

### Lubrication holes

When installing bearings, the lubrication holes shall be arranged in the non-loading areas.

For yoke type track rollers PWTR and NNTR, it is not necessary to specify the lubrication hole installation.

### NUTR

① Press fitting equipment  
As shown in the figure  
Press-fitting equipment shall be used to press-fit the yoke type track rollers

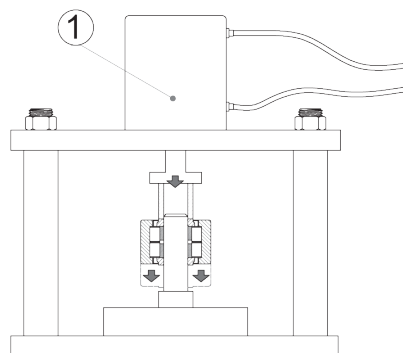

Axial location

The yoke type track rollers NUTR, PWTR and NNTR must be axially located.

PWTR..-2RS

① Hexagonal nuts  
Axial location as shown  
in the figure

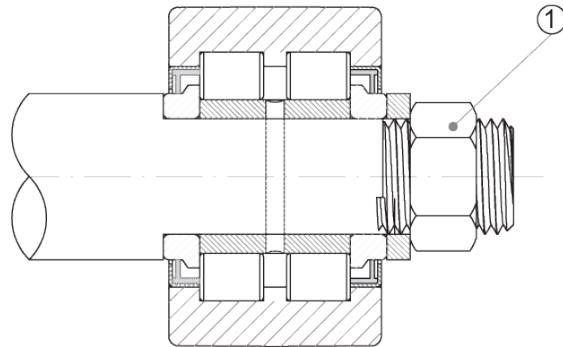

Installation and disassembly of  
stud type track rollers (needle  
rollers and cylindrical rollers)

If possible, stud type track rollers should be installed using press-fitting  
equipment.

Do not hit the flange of the support bolt.  
The radial lubrication hole is located on the flange end of the bolt.  
This location shall not be placed in the load-carrying area.

## Design and Use

Press-fit lube nozzle for stud type track rollers

The press-fit lube nozzle is provided along with the stud type track rollers in independent packages, which shall be press into the bearing correctly before installing the bearing.

KR..-PP  
As shown in the figure

Only the lube nozzle provided can be used (as shown in the table).  
If re-lubrication is carried out through the positioning hole, the axial lubrication hole of the stud type track rollers must be sealed with a lubrication nipple before installation.

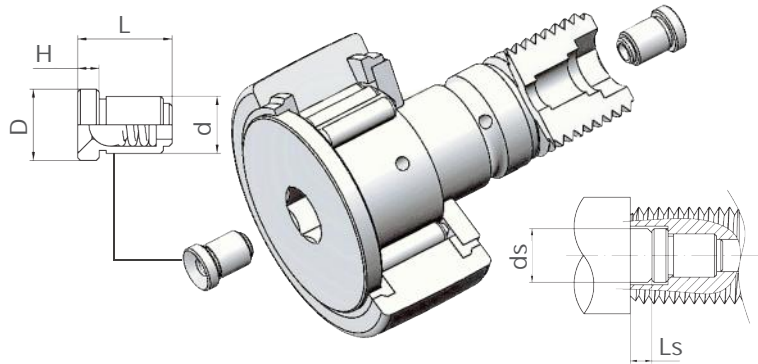

Dimensions of stud type track rollers and press-fit core shaft with press-fit lubrication nipple

Press-fit lubrication nipple

lubrication nipple	Dimension mm						Applicable outer diameter D
	D	d	L	h	ds ±0.1	L <sub>s</sub>	
NIPA1	6	4	6	1.5	-	-	16 and 19
NIPA1X4.5	4.7	4	4.5	1	4.5	5	22 to 32
NIPA1X7.5	7.5	6	7.5	2	7.5	6	35 to 52
NIPA3X9.5	10	8	9.5	3	10	9	62 to 90

For the length of lubrication nipple projection, please see the dimension table.

Axial location of stud type track rollers

Hexagonal nuts must be used to axially protect the stud type track rollers. When tightening the mounting nut or adjusting the eccentric locking collar, you can use a hexagonal wrench to hold the bearing at the long slot or hexagonal hole at the end of the support bolt. In case of severe vibrations, self-locking nuts or special locking washers according to DIN 985 can be used.

① Hexagonal wrench  
As shown in the figure  
Rolling stud type track rollers with eccentric locking collar by holding the bearing with hexagonal wrench

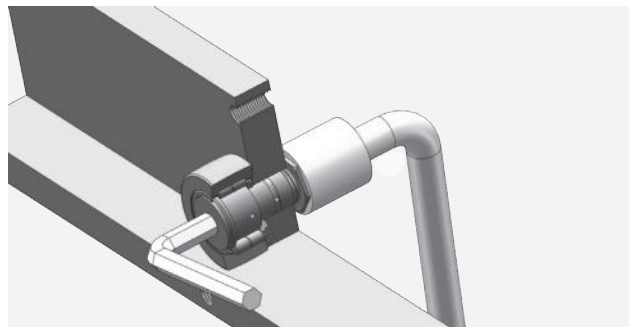

The highest point of the eccentric locking collar is marked on one side of the bolt flange.

## Initial operation and re-lubrication

stud type track rollers has a lubrication hole for re-lubrication:

1. At one side of the flange of the support bolt
2. At the end of the thread side, with the outer diameter starting from 22mm
3. On the handle of the support bolt, with the outer diameter starting from 30mm, and the lubrication slot in place.

Stud type track rollers with eccentric locking collars shall not be re-lubricated through bolts. The eccentric locking collar covers the lubrication hole. For lubrication, only the grease gun with the opening angle of  $\leq 60^\circ$  and with needle point nozzle could be used. Before the initial operation, the lubrication holes and greasing tubes shall be filled with grease for anti-corrosion and lubrication.

If a rolling element is fixed on the Radial lubrication hole, it will be difficult to lubricate. For safety, re-lubrication shall be carried out after the running of the bearing while it is still releasing heat and rotating, or before the bearing stops running or prolonging the running interval. The grease used initially must be refilled for re-lubrication. Before using different grease, its miscibility and compatibility must be checked.

The re-lubrication shall be continued until new grease is seen at the seal gaps. The used grease must be able to flow out of the bearing without trouble.

- ① Needle point nozzle with the opening angle of  $\leq 60^\circ$   
As shown in the figure  
Using grease gun for re-lubrication

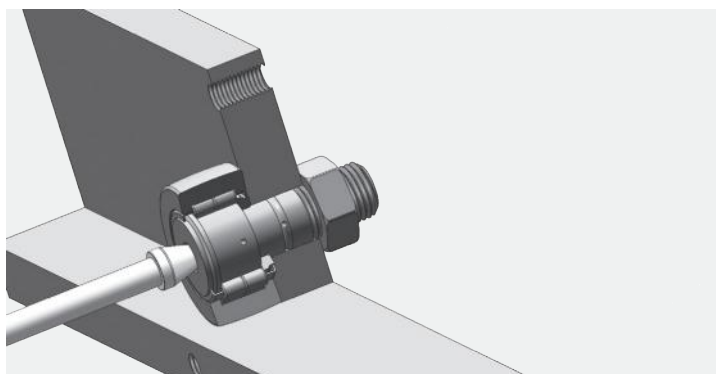

## Accuracy

The dimensional and geometrical tolerances shall be in accordance with DIN 620 and the standard bearings are Class PN, KR(E) and KRV shall be in accordance with ISO 7063.

The following deviations in DIN 620 shall be used:

1. The diameter tolerance of the optimized outer surface is  $0/-0.05$  mm
2. For NNTR, the diameter tolerance is h10
3. For NATR, NATV, NUTR, PWTR... -2RS, the width tolerance B is h12
4. For stud type track rollers, the tolerance of the support bolt shaft diameter is h7, and the tolerance of the eccentric locking collar is h9.

## Design and Use

### Internal radial clearance

The internal radial clearance of bearings approximately corresponds to the C2 group in DIN 620-4, and that for STO and NA22...-2RSR corresponds to CN group.

Inner diameter d mm		Internal radial clearance							
		C2 um		CN um		C3 um		C4 um	
Higher than	To	min.	max.	min.	max.	min.	max.	min.	max.
-	24	0	25	20	45	35	60	50	75
24	30	0	25	20	45	35	60	50	75
30	40	5	30	25	50	45	70	60	85
40	50	5	35	30	60	50	80	70	100
50	65	10	40	40	70	60	90	80	110
65	80	10	45	40	75	65	100	90	125
80	100	15	50	50	85	75	110	105	140
100	120	15	55	50	90	85	125	125	165
120	140	15	60	60	105	100	145	145	190

### Envelope circle

For RSTO and RNA22... -2RSR, the tolerance band of the envelope circle of its needle rollers  $F_w$  is F6.

The envelope circle is the inner joint circle when there is no clearance contact between the needle rollers and the adjacent structure.

### Internal radial clearance (Ball bearing track rollers)

Inner diameter d mm		Internal radial clearance									
		C2 um		CN um		C3 um		C4 um		C5 um	
Higher than	To	min.	max.	min.	max.	min.	max.	min.	max.	min.	max.
2.5	10	0	7	2	13	8	23	14	29	20	37
10	18	0	9	3	18	11	25	18	33	25	45
18	24	0	10	5	20	13	28	20	36	28	48
24	30	1	11	5	20	13	28	23	41	30	53
30	40	1	11	6	20	15	33	28	46	40	64
40	50	1	11	6	23	18	36	30	51	45	73
50	65	1	15	8	28	23	43	38	61	55	90

## Product Description - Combined Bearings

### THB Combined Bearings

#### Product characteristics

The composite raceway structure design can benefit clients with reduced design and use costs, which can be fitted with the high-rigidity track that can withstand high radial and axial loads to provide high dynamic and static load carrying capacity. The load-carrying capacity could be uniformly distributed on the guide to increase the service lives of the bearing and track, which can be assembled directly by welding bolts in an economic and convenient way. The bearing can be easily replaced so that it is widely used in mechanical, lifting and handling facilities.

#### Lubrication

THB combined bearings without re-lubrication holes are of fully enclosed construction and are fully filled with grease at the factory. This may ensure the normal use cycle of the bearings.

In the ordinary indoor environment such as in warehouses and plants, the surface of the rollers shall only be applied with protective lubrication oil every six months. To prolong the service life, THB combined bearings can generally be re-lubricated, and the relubrication hole will be plugged with M6 thread plug at the factory.

Under special conditions exposed to high dust, heavy pollution, high humidity, outdoor conditions, temperatures over 40°C, frequent load changes (continuous operation) and heavy loads, the combined bearings should be lubricated at least once a month. #3 grease is recommended to lubricate the THB bearings (such as Shell GadusS2 V100 3). Guide rails should be coated with an appropriate amount of grease for protection during operation.

For THB bearings with diameter of less than 100mm, all bearing components must be disassembled before welding.

For THB bearings with the outer diameter of more than 100mm, they should be welded on both sides of the bolt.

After the bearings have been installed and adjusted, the front screws should be secured with thread adhesive.

To prevent cracks in welded joints, welding rods and core wires for welding non-alloy steel shall be used.

For bearings with the welding diameter of lower than 100mm, all bearing components must be disassembled.

#### Tolerance

The tolerance shall comply with DIN620. For other unspecified dimensions, ISO 2768-m shall prevail.

Accuracy level: Generally, the accuracy shall reach level P0, and if you have any special requirements, please contact THB technical department.

Rated load and service life: ISO 76 and ISO 281.

#### Specification of THB Combined Bearings

Outer ring: Surface hardened steel, UNI 16CrNi4 or GB 20CrMnTi, the surface hardness is HRC60±2 after heat treatment. Inner ring: bearing steel, En 31-SAE 52100 or GB GCr15, the hardness is HRC60±2 after heat treatment. Rolling elements: Bearing steel, En 31-SAE 52100 or GB GCr15, the hardness is HRC62±2 after heat treatment.

Block: C22E or steel 20, annealed to facilitate welding

Support frame: C45 or steel 45, tempered

Bolt tolerance -0.05mm

Ordinary products can be re-lubricated

The working temperature of THB combined bearings is from -20 °C to +80 °C.

If you need products that can work at high temperatures, please contact THB technical department.

The maximum linear speed of steel THB combined bearings is 3m/s.



Standard combined bearings with coupling screw hole KB (4.072-4.080)

Precision combined bearings with coupling screw hole KB PR (4.072-4.080)

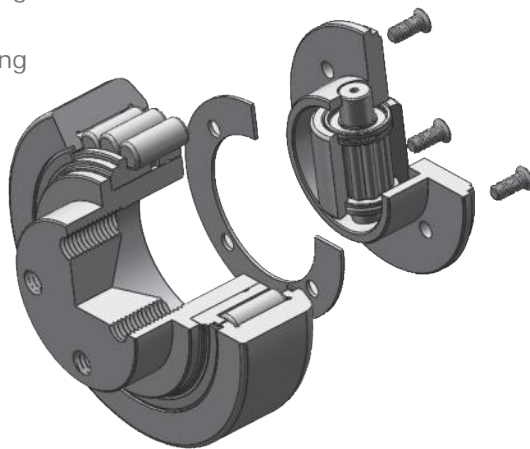

Standard radial roller bearing (2.054-2.063)

Precision radial roller bearing PR (2.054-2.063)

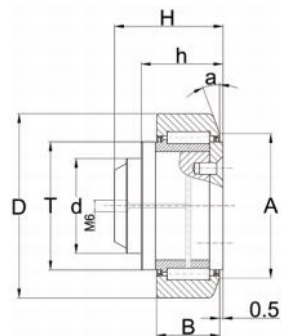
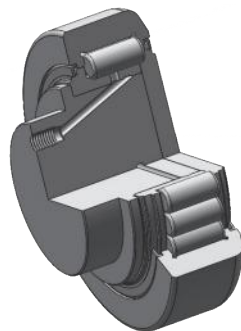

# Parameter sheet

## Yoke Type Track Rollers

No axially guided open type

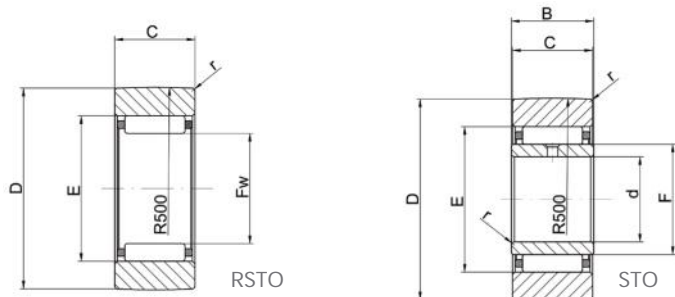

Without inner ring model	Mass	With inner ring model	Mass	Dimension							Basic rated load		Fatigue limit Load	Rotation speed
				D	d	C	B	F <sup>1)</sup> F <sub>w</sub>	E	r <sub>min</sub>	C <sub>rw</sub> N	C <sub>0rw</sub> N		
	g		g	D	d	C	B	F <sup>1)</sup> F <sub>w</sub>	E	r <sub>min</sub>	C <sub>rw</sub> N	C <sub>0rw</sub> N	C <sub>urw</sub> N	n <sub>DG</sub> r/min
RSTO 5 TV	8.5	-	-	16	-	7.8	-	7	10	0.3	2500	2550	300	15000
RSTO 6 TV	12.5	STO 6 TV	17	19	6	9.8	10	10	13	0.3	3740	4500	600	8000
RSTO 8 TV	21	STO 8 TV	26	24	8	9.8	10	12	15	0.3	4150	5400	700	7000
RSTO 10	42	STO 10	49	30	10	11.8	12	14	20	0.3	8300	9000	1200	5600
RSTO 12	49	STO 12	57	32	12	11.8	12	16	22	0.3	8900	9900	1300	4600
RSTO 15	50	STO 15	63	35	15	11.8	12	20	26	0.3	9100	10600	1400	3400
RSTO 17	88	STO 17	107	40	17	15.8	16	22	29	0.3	14200	17600	2200	2800
RSTO 20	130	STO 20	152	47	20	15.8	16	25	32	0.3	16100	21300	3000	2400
RSTO 25	150	STO 25	177	52	25	15.8	16	30	37	0.3	16300	23000	3200	1800
RSTO 30	255	STO 30	308	62	30	19.8	20	38	46	0.6	23000	34500	4700	1300
RSTO 35	375	STO 35	441	72	35	19.8	20	42	50	0.6	24600	40000	5400	1100
RSTO 40	420	STO 40	530	80	40	19.8	20	50	58	1	23700	39000	5800	850
RSTO 45	453	STO 45	576	85	45	19.8	20	55	63	1	25000	43000	5800	750
RSTO 50	481	STO 50	617	90	50	19.8	20	60	68	1	25500	45000	6200	650

1) F=diameter of inner ring raceway

F<sub>w</sub> = tolerance zone of needle envelope circle is F6

## Yoke Type Track Rollers

No axial guide

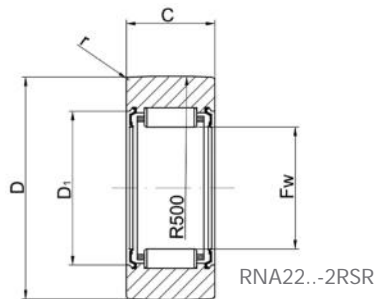

Without inner ring model	Mass g	Dimension					Basic rated load			Fatigue limit Load C <sub>urw</sub> N	Rotation speed n <sub>DG</sub> r/min
		D	C	F <sub>w</sub> <sup>1)</sup>	D <sub>1 min</sub>	r <sub>min</sub>	C <sub>rw</sub> N	C <sub>0rw</sub> N			
RNA 22/6 2RSR	18	19	11.8	10	16	0.3	3900	3365	485	8000	
RNA 22/8 2RSR	29	24	11.8	12	18	0.3	4750	4250	620	7000	
RNA 2200 2RSR	52	30	13.8	14	20	0.6	7000	6800	1060	5400	
RNA 2201 2RSR	57	32	13.8	16	22	0.6	7400	8200	1250	4600	
RNA 2202 2RSR	60	35	13.8	20	26	0.6	7550	9600	1350	3300	
RNA 2203 2RSR	94	40	15.8	22	28	1	9800	13000	1800	2900	
RNA 2204 2RSR	152	47	17.8	25	33	1	13500	18800	2600	2300	
RNA 2205 2RSR	179	52	17.8	30	38	1	14000	20500	2800	1750	
RNA 2206 2RSR	284	62	19.8	35	43	1	17000	25000	3500	1400	
RNA 2207 2RSR	432	72	22.7	42	50	1.1	21000	35500	5150	1100	
RNA 2208 2RSR	530	80	22.7	48	57	1.1	26000	40000	5200	850	

1) F=diameter of inner ring raceway

F<sub>w</sub> = tolerance zone of needle envelope circle is F6

# Parameter sheet

Yoke Type Track Rollers

No axial guide

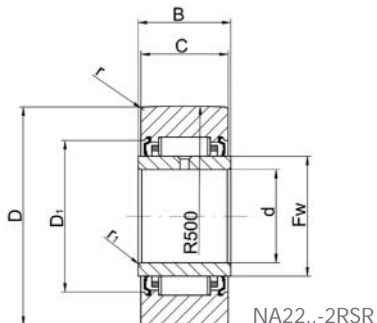

With inner ring model	Mass	Dimension								Basic rated load		Fatigue limit	Rotation speed
		g	D	d	C	B	$F_w^{1)}$	$D_{1\min}$	$r_{\min}$	$r_{1\min}$	Dynamic load $C_{rw}$ N	Static load $C_{0rw}$ N	Load $C_{urw}$ N
NA 22/6 2RSR	22	19	6	11.8	12	10	16	0.3	0.3	3900	3650	485	8000
NA 22/8 2RSR	34	24	8	11.8	12	12	18	0.3	0.3	4750	4250	620	7000
NA 2200 2RSR	60	30	10	13.8	14	14	20	0.6	0.3	7000	6800	1060	5400
NA 2201 2RSR	67	32	12	13.8	14	16	22	0.6	0.3	7400	8200	1250	4600
NA 2202 2RSR	75	35	15	13.8	14	20	26	0.6	0.3	7550	9600	1350	3300
NA 2203 2RSR	112	40	17	15.8	16	22	28	1	0.3	9800	13000	1800	2900
NA 2204 2RSR	177	47	20	17.8	18	25	33	1	0.3	13500	18800	2600	2300
NA 2205 2RSR	209	52	25	17.8	18	30	38	1	0.3	14000	20500	2800	1750
NA 2206 2RSR	324	62	30	19.8	20	35	43	1	0.3	17000	25000	3500	1400
NA 2207 2RSR	505	72	35	22.7	23	42	50	1.1	0.6	21000	35500	5150	1100
NA 2208 2RSR	628	80	40	22.7	23	48	57	1.1	0.6	26000	40000	5200	850
NA 2210 2RSR	690	90	50	22.7	23	58	68	1.1	0.6	26000	42000	5500	650

1) F=diameter of inner ring raceway

$F_w$  = tolerance zone of needle envelope circle is F6

## Yoke Type Track Rollers

With axial guide clearance seal or flat washer

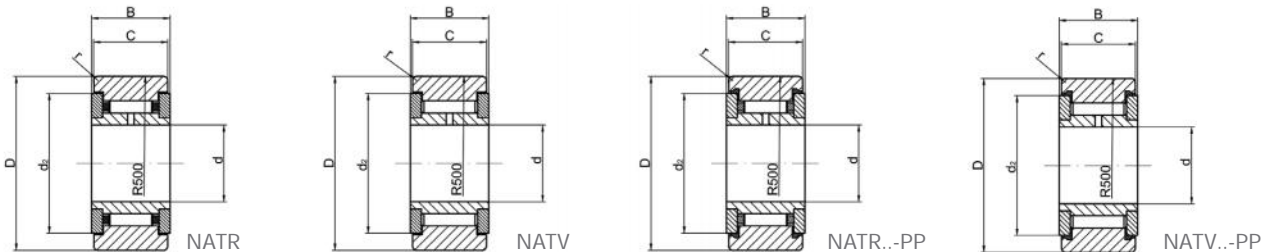

Model <sup>1)</sup>	Mass	Model <sup>2)</sup>	Mass	Dimension						Basic rated load		Fatigue limit Load	Rotation speed
				D	d	B	C	d <sub>2</sub>	r <sub>min</sub>	Dynamic load C <sub>rw</sub> N	Static load C <sub>0rw</sub> N		
NATR 5	14	NATR 5 PP	14	16	5	12	11	12.5	0.15	3150	3300	440	13000
NATV 5	15	NATV 5 PP	15	16	5	12	11	12.5	0.15	4800	6550	900	3800
NATR 6	20	NATR 6 PP	19	19	6	12	11	15	0.15	3480	3900	520	10000
NATV 6	21	NATV 6 PP	21	19	6	12	11	15	0.15	5300	8000	1150	3000
NATR 8	41	NATR 8 PP	38	24	8	15	14	19	0.3	5400	6500	910	7400
NATV 8	42	NATV 8 PP	41	24	8	15	14	19	0.3	7600	11200	1550	2400
NATR 10	64	NATR 10 PP	61	30	10	15	14	23	0.6	6500	8400	1200	5400
NATV 10	65	NATV 10 PP	64	30	10	15	14	23	0.6	9200	14600	2040	2100
NATR 12	71	NATR 12 PP	66	32	12	15	14	25	0.6	6800	8800	1250	4400
NATV 12	72	NATV 12 PP	69	32	12	15	14	25	0.6	9600	15500	2150	1800
NATR 15	104	NATR 15 PP	95	35	15	19	18	27.6	0.6	9600	14000	1800	3600
NATV 15	109	NATV 15 PP	101	35	15	19	18	27.6	0.6	12400	23000	3200	1600
NATR 17	144	NATR 17 PP	139	40	17	21	20	31.5	1	10600	15500	2080	2900
NATV 17	152	NATV 17 PP	147	40	17	21	20	31.5	1	14500	26000	3500	1300
NATR 20	246	NATR 20 PP	236	47	20	25	24	36.5	1	15000	25000	3300	2400
NATV 20	254	NATV 20 PP	245	47	20	25	24	36.5	1	20100	41000	5800	1300
NATR 25	275	NATR 25 PP	271	52	25	25	24	41.5	1	15000	26500	3550	1700
NATV 25	285	NATV 25 PP	281	52	25	25	24	41.5	1	20100	43000	6100	1000
NATR 30	470	NATR 30 PP	444	62	30	29	28	51	1	23000	38000	5000	1200
NATV 30	481	NATV 30 PP	468	62	30	29	28	51	1	29000	62000	8700	850
-	-	NATR 35 PP	547	72	35	29	28	58	1.1	24600	44000	5800	1000
-	-	NATV 35 PP	630	72	35	29	28	58	1.1	32000	69000	10000	750
-	-	NATR 40 PP	795	80	40	32	30	66	1.1	31900	57000	8200	850
-	-	NATV 40 PP	832	80	40	32	30	66	1.1	39000	88000	12000	650
-	-	NATR 50 PP	867	90	50	32	30	76	1.1	30800	58000	8000	650
-	-	NATV 50 PP	969	90	50	32	30	76	1.1	38500	91000	13500	550

1) Bearing with radius of curvature R=500mm and clearance seal

2) Bearing with plastic flat washer and optimized THB contour

Permissible range of operating temperature: -30 °C - +100°C (continuous operation)

# Parameter sheet

Yoke Type Track Rollers

With axial guide

Laminated seal at both sides

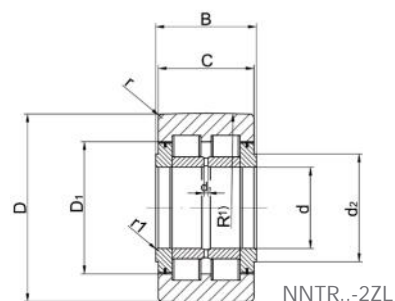

Model <sup>1)</sup>	Mass	Dimension						Mounting dimension			No.s of oil hole
		g	Dh <sub>10</sub>	d	B	C	r <sub>min</sub>	r <sub>1 min</sub>	d <sub>2</sub>	D <sub>1</sub>	
NNTR 50X130X65 2ZL	5.2	130	50	65	63	3	2	63	80	3	3
NNTR 55X140X70 2ZL	6.4	140	55	70	68	3	2	73	91	4	3
NNTR 60X150X75 2ZL	7.8	150	60	75	73	3	2	78	97	4	3
NNTR 65X160X75 2ZL	8.8	160	65	75	73	3	2	82	103	5	3
NNTR 70X180X85 2ZL	13	180	70	85	83	3	2	92	115	5	3
NNTR 80X200X90 2ZL	16.8	200	80	90	88	4	2	102	127	5	3
NNTR 90X220X100 2ZL	22.5	220	90	100	98	4	2.5	119	146	5	3
NNTR 100X240X105 2ZL	28	240	100	105	103	4	2.5	132	160	6	6
NNTR 110X260X115 2ZL	35.6	260	110	115	113	4	2.5	143	174	6	6
NNTR 120X290X135 2ZL	52.8	290	120	135	133	4	3	155	191	8	6
NNTR 130X310X146 2ZL	65.2	310	130	146	144	5	3	165	204	8	6

1) Curvature radius R = 10000 for NNTR50X130X65 2ZL to NNTR110X260X115 2ZL

R = 15000 for NNTR120X290X135 2ZL to NNTR130X310X146 2ZL

Basic rated load				Fatigue limit	Rotation speed	Model
Dynamic load	Static load	Dynamic load	Static load	Load		
$C_{rw}$ N	$C_{0rw}$ N	$F_{r\ per}$ N	$F_{0r\ per}$ N	$C_{urw}$ N	$n_{DG}$ r/min	
192000	260000	260000	260000	36000	1100	<a href="#">NNTR 50X130X65 2ZL</a>
225000	313000	275000	313000	44000	850	<a href="#">NNTR 55X140X70 2ZL</a>
250000	362000	325000	362000	52000	800	<a href="#">NNTR 60X150X75 2ZL</a>
275000	393000	345000	394000	55500	700	<a href="#">NNTR 65X160X75 2ZL</a>
353000	507000	463000	507000	74500	600	<a href="#">NNTR 70X180X85 2ZL</a>
413000	607000	547000	607000	86500	500	<a href="#">NNTR 80X200X90 2ZL</a>
500000	748000	595000	748000	103000	400	<a href="#">NNTR 90X220X100 2ZL</a>
555000	865000	705000	865000	116000	340	<a href="#">NNTR 100X240X105 2ZL</a>
665000	1040000	820000	1040000	142000	300	<a href="#">NNTR 110X260X115 2ZL</a>
860000	1300000	1100000	1300000	186000	260	<a href="#">NNTR 120X290X135 2ZL</a>
1005000	1630000	1270000	1630000	215000	240	<a href="#">NNTR 130X310X146 2ZL</a>

# Parameter sheet

Yoke Type Track Rollers

With axial guide

Dual seal

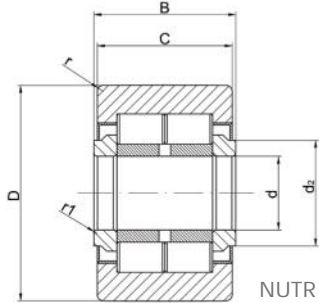

Model	Mass	Dimension							Basic rated load				Fatigue limit Load	Rotation speed $n_{DG}$ r/min
		g	D	d	B	C	$d_2$	$r_{min}$	$r_{1\ min}$	Dynamic load $C_{rw}$ N	Static load $C_{0rw}$ N	Dynamic load $F_{r\ per}$ N		
NUTR 15	99	35	15	19	18	20	0.6	0.3	15000	18500	8400	16500	2400	6000
PWTR 15 2RS	99	35	15	19	18	20	0.6	0.3	12500	14500	10500	14500	1750	5800
NUTR 17	147	40	17	21	20	22	1	0.5	18500	24600	12500	24500	3120	5400
PWTR 17 2RS	147	40	17	21	20	22	1	0.5	14000	17500	16000	17500	2100	4900
NUTR 1542	158	42	15	19	18	20	0.6	0.3	18000	24000	24000	24000	3000	6400
PWTR 1542 2RS	158	42	15	19	18	20	0.6	0.3	14500	16000	16000	16000	2100	6000
NUTR 1747	220	47	17	21	20	22	1	0.5	21200	30200	30200	30200	3800	5400
PWTR 1747 2RS	220	47	17	21	20	22	1	0.5	15800	18200	18200	18200	2420	5000
NUTR 20	245	47	20	25	24	27	1	0.5	28000	37000	16000	32000	4800	4100
PWTR 20 2RS	245	47	20	25	24	27	1	0.5	24000	30200	20500	30200	3700	3800
NUTR 2052	321	52	20	25	24	27	1	0.5	32000	43000	38000	43000	5600	4200
PWTR 2052 2RS	321	52	20	25	24	27	1	0.5	27000	34000	31000	34000	4230	3800
NUTR 25	281	52	25	25	24	31	1	0.5	28000	40300	17000	33500	5200	4200
PWTR 25 2RS	281	52	25	25	24	31	1	0.5	25000	32000	21500	32000	4100	3800
NUTR 2562	450	62	25	25	24	31	1	0.5	35000	53000	53000	53000	6800	4200
PWTR 2562 2RS	450	62	25	25	24	31	1	0.5	30000	42000	42000	42000	5200	3800
NUTR 30	465	62	30	29	28	38	1	0.5	40000	54500	23000	45000	7200	2500
PWTR 30 2RS	465	62	30	29	28	38	1	0.5	35000	45000	29000	45000	5700	2200

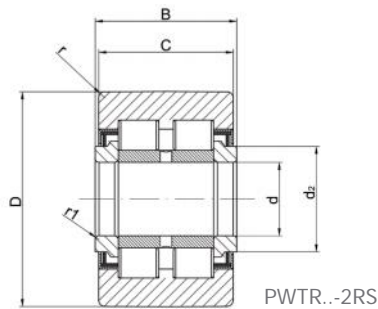

Model	Mass	Dimension								Basic rated load				Fatigue limit	Rotation speed
		D	d	B	C	d <sub>2</sub>	r <sub>min</sub>	r <sub>1 min</sub>	Dynamic load	Static load	Dynamic load	Static load	Load		
	g	D	d	B	C	d <sub>2</sub>	r <sub>min</sub>	r <sub>1 min</sub>	C <sub>rw</sub> N	C <sub>0rw</sub> N	F <sub>r per</sub> N	F <sub>0r per</sub> N	C <sub>urw</sub> N	n <sub>DG</sub> r/min	
NUTR 3072	697	72	30	29	28	38	1	0.5	47000	70000	66000	70000	9100	2600	
PWTR 3072 2RS	697	72	30	29	28	38	1	0.5	40500	55000	54000	55000	7100	2200	
NUTR 35	630	72	35	29	28	44	1.1	0.6	44000	62000	31000	62000	8600	2100	
PWTR 35 2RS	630	72	35	29	28	44	1.1	0.6	38000	53000	38000	53000	6800	1800	
NUTR 3580	836	80	35	29	28	44	1.1	0.6	50500	77000	75000	77000	10200	2100	
PWTR 3580 2RS	836	80	35	29	28	44	1.1	0.6	43000	63000	58000	63000	8000	1800	
NUTR 40	816	80	40	32	30	50.5	1.1	0.6	54000	78000	30000	60000	10000	1600	
PWTR 40 2RS	816	80	40	32	30	50.5	1.1	0.6	43000	60000	39000	60000	7800	1500	
NUTR 45	883	85	45	32	30	55.2	1.1	0.6	55000	81000	32000	61000	11400	1400	
PWTR 45 2RS	883	85	45	32	30	55.2	1.1	0.6	45000	62000	40500	62000	8100	1300	
NUTR 4090	1129	90	40	32	30	50.5	1.1	0.6	65000	100500	82000	100500	13500	1600	
PWTR 4090 2RS	1129	90	40	32	30	50.5	1.1	0.6	51000	74000	65000	74000	9500	1500	
NUTR 50	950	90	50	32	30	59.8	1.1	0.6	55000	85000	32000	62000	11500	1300	
PWTR 50 2RS	950	90	50	32	30	59.8	1.1	0.6	45000	65000	41500	65000	8400	1100	
NUTR 45100	1396	100	45	32	30	55.2	1.1	0.6	70000	114000	105000	112000	15500	1400	
PWTR45 100 2RS	1396	100	45	32	30	55.2	1.1	0.6	55000	83000	83000	83000	10600	1300	
NUTR 50110	1690	110	50	32	30	59.8	1.1	0.6	75000	125000	125000	125000	17000	1300	
PWTR 50110 2RS	1690	110	50	32	30	59.8	1.1	0.6	58000	93000	93000	93000	12000	1100	

# Parameter sheet

## Stud Type Track Rollers

With axial guide

Open or seal

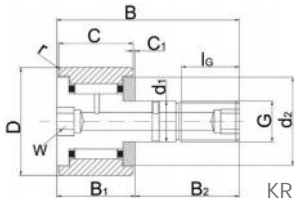

KR (R=500mm)  
CF..BR

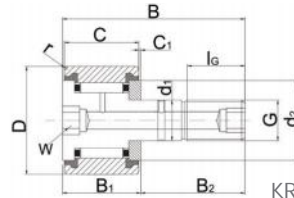

KR...-PP (R=500mm)  
CF..BUUR

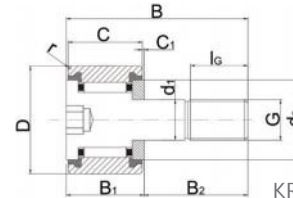

KR...-SK-PP (R=500mm)  
KRV 16, KRV 19 PP

Model	British system	Mass	Model with eccentric locking collar	Mass	Dimension												
		g		g	D	d <sub>1</sub> h7	B	B <sub>1 max</sub>	B <sub>2</sub>	B <sub>3</sub>	C	C <sub>1</sub>	r <sub>min</sub>	d <sub>2</sub>	d <sub>3</sub>	G	
KR 16 <sup>3)</sup>	CF 6 BR	19	-	-	16	6	28	12.2	16	-	11	0.6	0.15	12.5	-	M6(X1)	
KR 16•PP <sup>3)</sup>	CF 6 BUUR	18	KRE 16 PP	20	16	6	28	12.2	16	-	11	0.6	0.15	12.5	-	M6(X1)	
KR 16 SK PP <sup>4)</sup>	-	19	-	-	16	6	28	12.2	16	-	11	0.6	0.15	12.5	-	M6(X1)	
KRV 16.PP <sup>3)</sup>	CF 6 VBUUR	19	-	-	16	6	28	12.2	16	-	11	0.6	0.15	12.5	-	M6(X1)	
KR 19 <sup>3)</sup>	CF 8 BR	29	-	-	19	8	32	12.2	20	-	11	0.6	0.15	15	-	M8(X1.25)	
KR 19 PP <sup>3)</sup>	CF 8 BUUR	29	KRE 19 PP	32	19	8	32	12.2	20	-	11	0.6	0.15	15	-	M8(X1.25)	
KR 19 SK PP <sup>4)</sup>	-	29	-	-	19	8	32	12.2	20	-	11	0.6	0.15	15	-	M8(X1.25)	
KRV19-PP <sup>3)</sup>	CF 8 VBUUR	31	-	-	19	8	32	12.2	20	-	11	0.6	0.15	15	-	M8(X1.25)	
KR 22	CF 10 BR	45	-	-	22	10	36	13.2	23	-	12	0.6	0.3	17.5	-	M10X1	
KR 22 PP	CF 10 BUUR	43	KRE 22 PP	47	22	10	36	13.2	23	-	12	0.6	0.3	17.5	-	M10X1	
KRV 22 PP	CF 10 VBUUR	45	-	-	22	10	36	13.2	23	-	12	0.6	0.3	17.5	-	M10X1	
KR 26	CF 10-1 BR	59	-	-	26	10	36	13.2	23	-	12	0.6	0.3	17.5	-	M10X1	
KR 26 PP	CF 10-1 BUUR	57	KRE 26 PP	62	26	10	36	13.2	23	-	12	0.6	0.3	17.5	-	M10X1	
KRV 26 PP	CF 10-1 VBUUR	59	-	-	26	10	36	13.2	23	-	12	0.6	0.3	17.5	-	M10X1	
KR 30	CF 12 BR	92	-	-	30	12	40	15.2	25	6	14	0.6	0.6	23	3	M12X1.5	
KR 30 PP	CF 12 BUUR	88	KRE 30 PP	93	30	12	40	15.2	25	6	14	0.6	0.6	23	3	M12X1.5	
KRV 30 PP	CF 12 VBUUR	91	-	-	30	12	40	15.2	25	6	14	0.6	0.6	23	3	M12X1.5	
KR 32	CF 12-1 BR	103	-	-	32	12	40	15.2	25	6	14	0.6	0.6	23	3	M12X1.5	
KR 32 PP	CF 12-1 BUUR	98	KRE 32 PP	104	32	12	40	15.2	25	6	14	0.6	0.6	23	3	M12X1.5	
KRV 32 PP	CF 12-1 VBUUR	101	-	-	32	12	40	15.2	25	6	14	0.6	0.6	23	3	M12X1.5	

1) Press-fit lube nozzle to be separately packed for delivery Only supplied lube nozzle to be allowed

2) Nominal dimension of inner hexagonal hole Centralized lube adapter to the central lube system

3) Relubrication hole available at the flange endface only, where a long slot used for rotation resistance is provided at installation

4) Inner hexagonal hole available at the flange endface only No relubrication unit

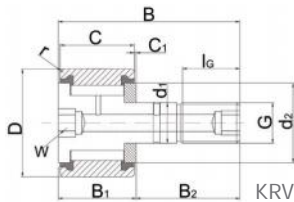

KRV...-PP (R=500mm)  
CF..VBUUR

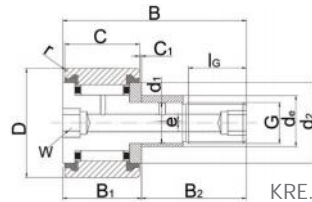

KRE...-PP (R=500mm)

Eccentric locking collar	Press-fit	Tightening torque	Basic rated load		Fatigue limit	Rotation speed	British system	Model					
			Dynamic load	Static load									
$l_G$	$W^{2)}$	$d_e$	$h9$	$B_e$	$e$	Lube nozzle <sup>1)</sup>	MA Nm	$C_{rw}$ N	$C_{orw}$ N	$C_{urw}$ N	$n_{DG}$ r/min		
8	-	-	-	-	-	NIPA1	3	3140	3300	440	13000	CF 6 BR	KR 16 <sup>3)</sup>
8	-	9	7	0.5	-	NIPA1	3	3140	3300	440	13000	CF 6 BUUR	KR 16•PP <sup>3)</sup>
8	4	-	-	-	-	-	3	3140	3300	440	13000	-	KR 16 SK PP <sup>4)</sup>
8	-	-	-	-	-	NIPA1	3	4800	6500	940	3800	CF 6 VBUUR	KRV 16.PP <sup>3)</sup>
10	-	-	-	-	-	NIPA1	8	3480	3800	520	10800	CF 8 BR	KR 19 <sup>3)</sup>
10	-	11	9	0.5	-	NIPA1	8	3480	3800	520	10800	CF 8 BUUR	KR 19-PP <sup>3)</sup>
10	4	-	-	-	-	-	8	3480	3800	520	10800	-	KR 19 SK PP <sup>4)</sup>
10	-	-	-	-	-	NIPA1	8	5300	7900	1150	3000	CF 8 VBUUR	KRV 19-PP <sup>3)</sup>
12	5	-	-	-	-	NIPA1X4.5	15	4500	5200	720	7800	CF 10 BR	KR 22
12	5	13	10	0.5	-	NIPA1X4.5	15	4500	5200	720	7800	CF 10 BUUR	KR 22 PP
12	5	-	-	-	-	NIPA1X4.5	15	6100	9000	1200	2500	CF 10 VBUUR	KRV 22 PP
12	5	-	-	-	-	NIPA1X4.5	15	5050	6300	820	7500	CF 10-1 BR	KR 26
12	5	13	10	0.5	-	NIPA1X4.5	15	5050	6300	820	7500	CF 10-1 BUUR	KR 26 PP
12	5	-	-	-	-	NIPA1X4.5	15	7200	11000	1450	2500	CF 10-1 VBUUR	KRV 26 PP
13	6	-	-	-	-	NIPA1X4.5	22	6700	8500	1200	5300	CF 12 BR	KR 30
13	6	15	11	0.5	-	NIPA1X4.5	22	6700	8500	1200	5300	CF 12 BUUR	KR 30 PP
13	6	-	-	-	-	NIPA1X4.5	22	9400	14800	2000	2050	CF 12 VBUUR	KRV 30 PP
13	6	-	-	-	-	NIPA1X4.5	22	7000	9100	1250	5300	CF 12-1 BR	KR 32
13	6	15	11	0.5	-	NIPA1X4.5	22	7000	9100	1250	5300	CF 12-1 BUUR	KR 32 PP
13	6	-	-	-	-	NIPA1X4.5	22	9800	16000	2150	2050	CF 12-1 VBUUR	KRV 32 PP

# Parameter sheet

Stud Type Track Rollers

With axial guide

Open or seal

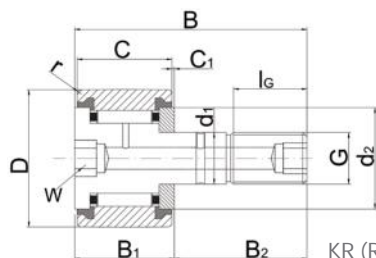

KR (R=500mm) KR...PP  
CF...BR

Model	British system	Mass	Model	Mass	Dimension											
		g		g	D	d <sub>1</sub> h7	B	B <sub>1 max</sub>	B <sub>2</sub>	B <sub>3</sub>	C	C <sub>1</sub>	r <sub>min</sub>	d <sub>2</sub>	d <sub>3</sub>	
KR 35	CF 16 BR	173	-	-	35	16	52	19.6	32.5	8	18	0.8	0.6	27.6	3	
KR 35 PP	CF 16 BUUR	164	KRE35 PP	177	35	16	52	19.6	32.5	8	18	0.8	0.6	27.6	3	
KRV 35 PP	CF 16 VBUUR	166	-	-	35	16	52	19.6	32.5	8	18	0.8	0.6	27.6	3	
KR 40	CF 18 BR	247	-	-	40	18	58	21.6	36.5	8	20	0.8	1	31.5	3	
KR 40 PP	CF 18 BUUR	239	KRE40 PP	255	40	18	58	21.6	36.5	8	20	0.8	1	31.5	3	
KRV 40 PP	CF 18 VBUUR	247	-	-	40	18	58	21.6	36.5	8	20	0.8	1	31.5	3	
KR 47 PP	CF 20-1 BUUR	381	KRE47 PP	400	47	20	66	25.6	40.5	9	24	0.8	1	36.5	4	
KRV 47 PP	CF 20-1 VBUUR	390	-	-	47	20	66	25.6	40.5	9	24	0.8	1	36.5	4	
KR 52 PP	CF 20 BUUR	454	KRE52 PP	473	52	20	66	25.6	40.5	9	24	0.8	1	36.5	4	
KRV 52 PP	CF 20 VBUUR	463	-	-	52	20	66	25.6	40.5	9	24	0.8	1	36.5	4	
KR 62 PP	CF 24 BUUR	770	KRE62 PP	798	62	24	80	30.6	49.5	11	29	0.8	1	44	4	
KRV 62 PP	CF 24 VBUUR	787	-	-	62	24	80	30.6	49.5	11	29	0.8	1	44	4	
KR 72 PP	CF 24-1 BUUR	1010	KRE72 PP	1038	72	24	80	30.6	49.5	11	29	0.8	1.1	44	4	
KRV 72 PP	CF 24-1 VBUUR	1027	-	-	72	24	80	30.6	49.5	11	29	0.8	1.1	44	4	
KR 80 PP	CF 30 BUUR	1608	KRE80 PP	1665	80	30	100	37	63	15	35	1	1.1	53	4	
KRV 80 PP	CF 30 VBUUR	1636	-	-	80	30	100	37	63	15	35	1	1.1	53	4	
KR 90 PP	CF 30-2 BUUR	1975	KRE90 PP	2032	90	30	100	37	63	15	35	1	1.1	53	4	
KRV 90 PP	CF 30-2 VBUUR	2003	-	-	90	30	100	37	63	15	35	1	1.1	53	4	

1) Press-fit lube nozzle to be separately packed for delivery Only supplied lube nozzle to be allowed

2) Nominal dimension of inner hexagonal hole Centralized lube adapter to the central lube system

3) Relubrication hole available at the flange endface only, where a long slot used for rotation resistance is provided at installation

4) Inner hexagonal hole available at the flange endface only No relubrication unit

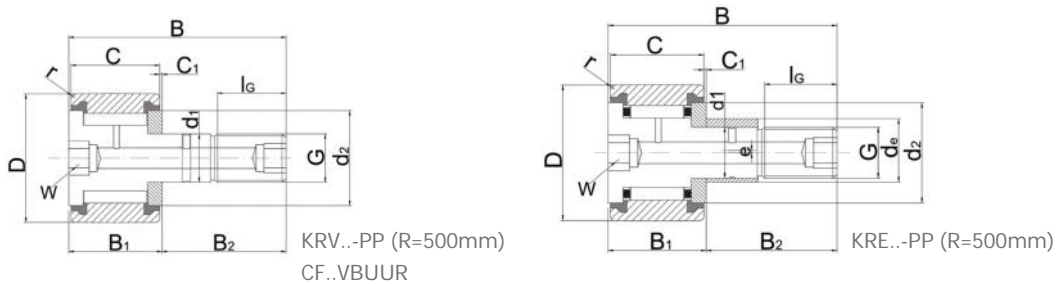

G	l <sub>G</sub>	W <sup>2)</sup>	Eccentric locking collar			Press-fit Lube nozzle <sup>1)</sup>	Tightening torque MA Nm	Basic rated load		Fatigue limit Load	Rotation speed n <sub>DG</sub> r/min	British system	Model
			d <sub>e</sub>	h <sub>9</sub>	B <sub>e</sub>			e	Dynamic load C <sub>rw</sub> N				
M16X1.5	17	8	-	-	-	NIPA2X7.5	58	9650	14200	1820	3600	CF 16 BR	KR 35
M16X1.5	17	8	20	14	1	NIPA2X7.5	58	9650	14200	1820	3600	CF 16 BUUR	KR 35 PP
M16X1.5	17	8	-	-	-	NIPA2X7.5	58	12500	23000	3150	1600	CF 16 VBUUR	KRV 35 PP
M18X1.5	19	8	-	-	-	NIPA2X7.5	87	10800	15700	2080	2900	CF 18 BR	KR 40
M18X1.5	19	8	22	16	1	NIPA2X7.5	87	10800	15700	2080	2900	CF 18 BUUR	KR 40 PP
M18X1.5	19	8	-	-	-	NIPA2X7.5	87	14500	26400	3480	1400	CF 18 VBUUR	KRV 40 PP
M20X1.5	21	10	24	18	1	NIPA2X7.5	120	15200	25900	3360	2400	CF 20-1 BUUR	KR 47 PP
M20X1.5	21	10	-	-	-	NIPA2X7.5	120	20100	41000	5800	1300	CF 20-1 VBUUR	KRV 47 PP
M20X1.5	21	10	24	18	1	NIPA2X7.5	120	16500	28500	3750	2400	CF 20 BUUR	KR 52 PP
M20X1.5	21	10	-	-	-	NIPA2X7.5	120	22100	47800	6650	1300	CF 20 VBUUR	KRV 52 PP
M24X1.5	25	14	28	22	1	NIPA3X9.5	220	25800	47800	6700	1900	CF 24 BUUR	KR 62 PP
M24X1.5	25	14	-	-	-	NIPA3X9.5	220	33300	74800	11100	1100	CF 24 VBUUR	KRV 62 PP
M24X1.5	25	14	28	22	1	NIPA3X9.5	220	27800	52800	7150	1900	CF 24-1 BUUR	KR 72 PP
M24X1.5	25	14	-	-	-	NIPA3X9.5	220	36300	84700	12500	1100	CF 24-1 VBUUR	KRV 72 PP
M30X1.5	32	14	35	29	1.5	NIPA3X9.5	450	38300	76800	10700	1300	CF 30 BUUR	KR 80 PP
M30X1.5	32	14	-	-	-	NIPA3X9.5	450	48200	116800	17200	850	CF 30 VBUUR	KRV 80 PP
M30X1.5	32	14	35	29	1.5	NIPA3X9.5	450	40200	82800	11600	1300	CF 30-2 BUUR	KR 90 PP
M30X1.5	32	14	-	-	-	NIPA3X9.5	450	51800	127000	18500	850	CF 30-2 VBUUR	KRV 90 PP

# Parameter sheet

## CF Inch roller series

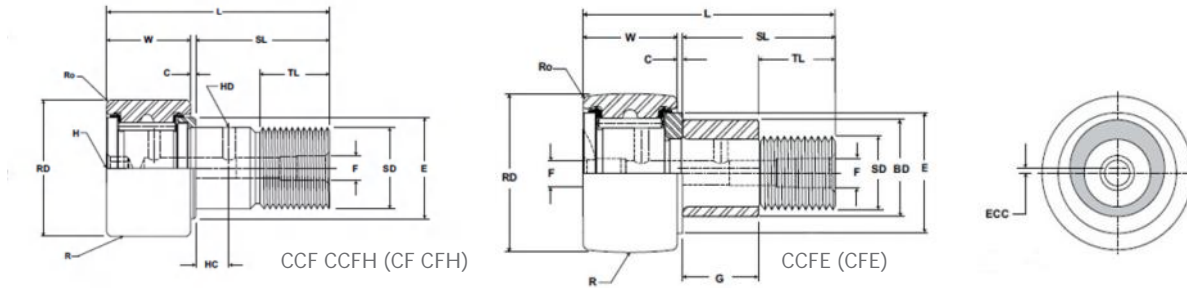

Bearing model		Structure dimension										Eccentric locking collar		
Sealless type	Seal type	RD mm	W		SD		SL	C	TL	L	R	ECC	G	
			Nom	Tol	Nom	Tol								Nom
CF 1/2	CF 1/2 S	12.70	+0/-0.03	9.53	+0 / -0.13	4.83	+0.03/-0	15.9	0.8	6.4	26.2	-	-	-
CF 1/2 B	CF 1/2 SB	12.70	+0/-0.03	9.53	+0 / -0.13	4.83	+0.03/-0	15.9	0.8	6.4	26.2	-	-	-
CCF 1/2	CCF 1/2 S	12.70	+0/-0.03	9.53	+0 / -0.13	4.83	+0.03/-0	15.9	0.8	6.4	26.2	178	-	-
CCF 1/2 B	CCF 1/2 SB	12.70	+0/-0.03	9.53	+0 / -0.13	4.83	+0.03/-0	15.9	0.8	6.4	26.2	178	-	-
CFE 1/2	CFE 1/2 S	12.70	+0/-0.03	9.53	+0 / -0.13	4.83	+0.03/-0	15.9	0.8	6.4	26.2	-	0.25	9.53
CFE 1/2 B	CFE 1/2 SB	12.70	+0/-0.03	9.53	+0 / -0.13	4.83	+0.03/-0	15.9	0.8	6.4	26.2	-	0.25	9.53
CCFE 1/2	CCFE 1/2 S	12.70	+0/-0.03	9.53	+0 / -0.13	4.83	+0.03/-0	15.9	0.8	6.4	26.2	178	0.25	9.53
CCFE 1/2 B	CCFE 1/2 SB	12.70	+0/-0.03	9.53	+0 / -0.13	4.83	+0.03/-0	15.9	0.8	6.4	26.2	178	0.25	9.53
CFH 1/2	CFH 1/2 S	12.70	+0/-0.03	9.53	+0 / -0.13	4.83	+0.03/-0	15.9	0.8	6.4	26.2	-	-	-
CFH 1/2 B	CFH 1/2 SB	12.70	+0/-0.03	9.53	+0 / -0.13	4.83	+0.03/-0	15.9	0.8	6.4	26.2	-	-	-
CCFH 1/2	CCFH 1/2 S	12.70	+0/-0.03	9.53	+0 / -0.13	4.83	+0.03/-0	15.9	0.8	6.4	26.2	178	-	-
CCFH 1/2 B	CCFH 1/2 SB	12.70	+0/-0.03	9.53	+0 / -0.13	4.83	+0.03/-0	15.9	0.8	6.4	26.2	178	-	-
CF 1/2 N	CF 1/2 N S	12.70	+0/-0.03	8.74	+0 / -0.13	4.83	+0.03/-0	12.7	0.8	6.4	22.2	-	-	-
CF 1/2 N B	CF 1/2 N SB	12.70	+0/-0.03	8.74	+0 / -0.13	4.83	+0.03/-0	12.7	0.8	6.4	22.2	-	-	-
CCF 1/2 N	CCF 1/2 N S	12.70	+0/-0.03	8.74	+0 / -0.13	4.83	+0.03/-0	12.7	0.8	6.4	22.2	152	-	-
CCF 1/2 N B	CCF 1/2 N SB	12.70	+0/-0.03	8.74	+0 / -0.13	4.83	+0.03/-0	12.7	0.8	6.4	22.2	152	-	-
CFE 1/2 N	CFE 1/2 N S	12.70	+0/-0.03	8.74	+0 / -0.13	4.83	+0.03/-0	12.7	0.8	6.4	22.2	-	0.25	6.35
CFE 1/2 N B	CFE 1/2 N SB	12.70	+0/-0.03	8.74	+0 / -0.13	4.83	+0.03/-0	12.7	0.8	6.4	22.2	-	0.25	6.35
CCFE 1/2 N	CCFE 1/2 N S	12.70	+0/-0.03	8.74	+0 / -0.13	4.83	+0.03/-0	12.7	0.8	6.4	22.2	152	0.25	6.35
CCFE 1/2 N B	CCFE 1/2 N SB	12.70	+0/-0.03	8.74	+0 / -0.13	4.83	+0.03/-0	12.7	0.8	6.4	22.2	152	0.25	6.35
CF 9/16	CF 9/16 S	14.29	+0/-0.03	9.53	+0 / -0.13	4.83	+0.03/-0	15.9	0.8	6.4	26.2	-	-	-
CF 9/16 B	CF 9/16 SB	14.29	+0/-0.03	9.53	+0 / -0.13	4.83	+0.03/-0	15.9	0.8	6.4	26.2	-	-	-
CCF 9/16	CCF 9/16 S	14.29	+0/-0.03	9.53	+0 / -0.13	4.83	+0.03/-0	15.9	0.8	6.4	26.2	178	-	-
CCF 9/16 B	CCF 9/16 SB	14.29	+0/-0.03	9.53	+0 / -0.13	4.83	+0.03/-0	15.9	0.8	6.4	26.2	178	-	-
CFE 9/16	CFE 9/16 S	14.29	+0/-0.03	9.53	+0 / -0.13	4.83	+0.03/-0	15.9	0.8	6.4	26.2	-	0.25	9.53
CFE 9/16 B	CFE 9/16 SB	14.29	+0/-0.03	9.53	+0 / -0.13	4.83	+0.03/-0	15.9	0.8	6.4	26.2	-	0.25	9.53
CCFE 9/16	CCFE 9/16 S	14.29	+0/-0.03	9.53	+0 / -0.13	4.83	+0.03/-0	15.9	0.8	6.4	26.2	178	0.25	9.53
CCFE 9/16 B	CCFE 9/16 SB	14.29	+0/-0.03	9.53	+0 / -0.13	4.83	+0.03/-0	15.9	0.8	6.4	26.2	178	0.25	9.53
CFH 9/16	CFH 9/16 S	14.29	+0/-0.03	9.53	+0 / -0.13	6.35	+0.03/-0	15.9	0.8	6.4	26.2	-	-	-
CFH 9/16 B	CFH 9/16 SB	14.29	+0/-0.03	9.53	+0 / -0.13	6.35	+0.03/-0	15.9	0.8	6.4	26.2	-	-	-
CCFH 9/16	CCFH 9/16 S	14.29	+0/-0.03	9.53	+0 / -0.13	6.35	+0.03/-0	15.9	0.8	6.4	26.2	178	-	-
CCFH 9/16 B	CCFH 9/16 SB	14.29	+0/-0.03	9.53	+0 / -0.13	6.35	+0.03/-0	15.9	0.8	6.4	26.2	178	-	-

BD	Rated load		Mounting dimension						Thread		Tightening torque	Limit speed (grease)	Weight
	Cr	Cor	HC mm	HD	F	E	Ro	Seat hole diameter HBD		WT			
±0.025	N		(Ref)	(Ref)	(Ref)	(Ref)	(Ref)	Nom	Tol	Nm	RPM	kg	
-	3,025	3,514	-	-	3.175	10.41	0.4	4.834	+0.005/-0.008	10-32	2	11,500	0.02
-	3,025	3,514	-	-	3.175	10.41	0.4	4.834	+0.005/-0.008	10-32	2	11,500	0.02
-	3,025	3,514	-	-	3.175	10.41	N/A	4.834	+0.005/-0.008	10-32	2	11,500	0.02
-	3,025	3,514	-	-	3.175	10.41	N/A	4.834	+0.005/-0.008	10-32	2	11,500	0.02
6.35	3,025	3,514	-	-	3.175	10.41	0.4	6.42	+0.025/-0.025	10-32	2	11,500	0.02
6.35	3,025	3,514	-	-	3.175	10.41	0.4	6.42	+0.025/-0.025	10-32	2	11,500	0.02
6.35	3,025	3,514	-	-	3.175	10.41	N/A	6.42	+0.025/-0.025	10-32	2	11,500	0.02
6.35	3,025	3,514	-	-	3.175	10.41	N/A	6.42	+0.025/-0.025	10-32	2	11,500	0.02
-	3,025	7,028	-	-	3.175	10.41	0.4	6.358	+0.005/-0.008	1/4-28	4	11,500	0.02
-	3,025	7,028	-	-	3.175	10.41	0.4	6.358	+0.005/-0.008	1/4-28	4	11,500	0.02
-	3,025	7,028	-	-	3.175	10.41	N/A	6.358	+0.005/-0.008	1/4-28	4	11,500	0.02
-	3,025	7,028	-	-	3.175	10.41	N/A	6.358	+0.005/-0.008	1/4-28	4	11,500	0.02
-	2,758	3,203	-	-	3.175	10.41	0.4	4.834	+0.005/-0.008	10-32	2	11,500	0.02
-	2,758	3,203	-	-	3.175	10.41	0.4	4.834	+0.005/-0.008	10-32	2	11,500	0.02
-	2,758	3,203	-	-	3.175	10.41	N/A	4.834	+0.005/-0.008	10-32	2	11,500	0.02
-	2,758	3,203	-	-	3.175	10.41	N/A	4.834	+0.005/-0.008	10-32	2	11,500	0.02
6.35	2,758	3,203	-	-	3.175	10.41	0.4	6.42	+0.025/-0.025	10-32	2	11,500	0.02
6.35	2,758	3,203	-	-	3.175	10.41	0.4	6.42	+0.025/-0.025	10-32	2	11,500	0.02
6.35	2,758	3,203	-	-	3.175	10.41	N/A	6.42	+0.025/-0.025	10-32	2	11,500	0.02
6.35	2,758	3,203	-	-	3.175	10.41	N/A	6.42	+0.025/-0.025	10-32	2	11,500	0.02
-	3,025	3,514	-	-	3.175	10.41	0.4	4.834	+0.005/-0.008	10-32	2	10,000	0.02
-	3,025	3,514	-	-	3.175	10.41	0.4	4.834	+0.005/-0.008	10-32	2	10,000	0.02
-	3,025	3,514	-	-	3.175	10.41	N/A	4.834	+0.005/-0.008	10-32	2	10,000	0.02
-	3,025	3,514	-	-	3.175	10.41	N/A	4.834	+0.005/-0.008	10-32	2	10,000	0.02
6.35	3,025	3,514	-	-	3.175	10.41	0.4	6.42	+0.025/-0.025	10-32	2	10,000	0.02
6.35	3,025	3,514	-	-	3.175	10.41	0.4	6.42	+0.025/-0.025	10-32	2	10,000	0.02
6.35	3,025	3,514	-	-	3.175	10.41	N/A	6.42	+0.025/-0.025	10-32	2	10,000	0.02
6.35	3,025	3,514	-	-	3.175	10.41	N/A	6.42	+0.025/-0.025	10-32	2	10,000	0.02
-	3,025	7,028	-	-	3.175	10.41	0.4	6.358	+0.005/-0.008	1/4-28	4	10,000	0.02
-	3,025	7,028	-	-	3.175	10.41	0.4	6.358	+0.005/-0.008	1/4-28	4	10,000	0.02
-	3,025	7,028	-	-	3.175	10.41	N/A	6.358	+0.005/-0.008	1/4-28	4	10,000	0.02
-	3,025	7,028	-	-	3.175	10.41	N/A	6.358	+0.005/-0.008	1/4-28	4	10,000	0.02

# Parameter sheet

## CF Inch roller series

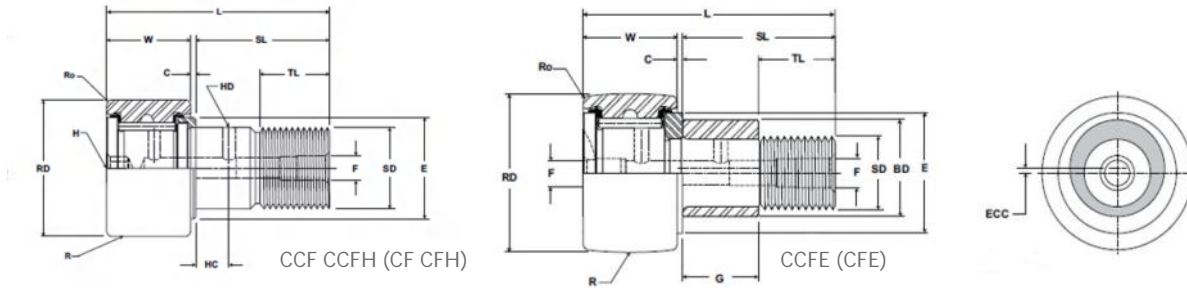

Bearing model		Structure dimension										Eccentric locking collar		
Sealless type	Seal type	RD mm	W		SD		SL	C	TL	L	R	ECC	G	
			Nom	Tol	Nom	Tol								Nom
CF 5/8	CF 5/8 S	15.88	+0/-0.03	11.11	+0 / -0.13	6.35	+0.03/-0	19.1	0.8	7.9	31.0	-	-	-
CF 5/8 B	CF 5/8 SB	15.88	+0/-0.03	11.11	+0 / -0.13	6.35	+0.03/-0	19.1	0.8	7.9	31.0	-	-	-
CCF 5/8	CCF 5/8 S	15.88	+0/-0.03	11.11	+0 / -0.13	6.35	+0.03/-0	19.1	0.8	7.9	31.0	203	-	-
CCF 5/8 B	CCF 5/8 SB	15.88	+0/-0.03	11.11	+0 / -0.13	6.35	+0.03/-0	19.1	0.8	7.9	31.0	203	-	-
CFE 5/8	CFE 5/8 S	15.88	+0/-0.03	11.11	+0 / -0.13	6.35	+0.03/-0	19.1	0.8	7.9	31.0	-	0.38	11.10
CFE 5/8 B	CFE 5/8 SB	15.88	+0/-0.03	11.11	+0 / -0.13	6.35	+0.03/-0	19.1	0.8	7.9	31.0	-	0.38	11.10
CCFE 5/8	CCFE 5/8 S	15.88	+0/-0.03	11.11	+0 / -0.13	6.35	+0.03/-0	19.1	0.8	7.9	31.0	203	0.38	11.10
CCFE 5/8 B	CCFE 5/8 SB	15.88	+0/-0.03	11.11	+0 / -0.13	6.35	+0.03/-0	19.1	0.8	7.9	31.0	203	0.38	11.10
CFH 5/8	CFH 5/8 S	15.88	+0/-0.03	11.11	+0 / -0.13	7.94	+0.03/-0	19.1	0.8	7.9	31.0	-	-	-
CFH 5/8 B	CFH 5/8 SB	15.88	+0/-0.03	11.11	+0 / -0.13	7.94	+0.03/-0	19.1	0.8	7.9	31.0	-	-	-
CCFH 5/8	CCFH 5/8 S	15.88	+0/-0.03	11.11	+0 / -0.13	7.94	+0.03/-0	19.1	0.8	7.9	31.0	203	-	-
CCFH 5/8 B	CCFH 5/8 SB	15.88	+0/-0.03	11.11	+0 / -0.13	7.94	+0.03/-0	19.1	0.8	7.9	31.0	203	-	-
CF 5/8 N	CF 5/8 N S	15.88	+0/-0.03	10.31	+0 / -0.13	6.35	+0.03/-0	15.9	0.8	7.9	27.0	-	-	-
CF 5/8 N B	CF 5/8 N SB	15.88	+0/-0.03	10.31	+0 / -0.13	6.35	+0.03/-0	15.9	0.8	7.9	27.0	-	-	-
CCF 5/8 N	CCF 5/8 N S	15.88	+0/-0.03	10.31	+0 / -0.13	6.35	+0.03/-0	15.9	0.8	7.9	27.0	178	-	-
CCF 5/8 N B	CCF 5/8 N SB	15.88	+0/-0.03	10.31	+0 / -0.13	6.35	+0.03/-0	15.9	0.8	7.9	27.0	178	-	-
CCFE 5/8 N		15.88	+0/-0.03	10.31	+0 / -0.13	6.35	+0.03/-0	15.9	0.8	7.9	27.0	178	0.38	11.10
CF 11/16	CF 11/16 S	17.46	+0/-0.03	11.11	+0 / -0.13	6.35	+0.03/-0	19.1	0.8	7.9	31.0	-	-	-
CF 11/16 B	CF 11/16 SB	17.46	+0/-0.03	11.11	+0 / -0.13	6.35	+0.03/-0	19.1	0.8	7.9	31.0	-	-	-
CCF 11/16	CCF 11/16 S	17.46	+0/-0.03	11.11	+0 / -0.13	6.35	+0.03/-0	19.1	0.8	7.9	31.0	203	-	-
CCF 11/16 B	CCF 11/16 SB	17.46	+0/-0.03	11.11	+0 / -0.13	6.35	+0.03/-0	19.1	0.8	7.9	31.0	203	-	-
CFE 11/16	CFE 11/16 S	17.46	+0/-0.03	11.11	+0 / -0.13	6.35	+0.03/-0	19.1	0.8	7.9	31.0	-	0.38	11.10
CFE 11/16 B	CFE 11/16 SB	17.46	+0/-0.03	11.11	+0 / -0.13	6.35	+0.03/-0	19.1	0.8	7.9	31.0	-	0.38	11.10
CCFE 11/16	CCFE 11/16 S	17.46	+0/-0.03	11.11	+0 / -0.13	6.35	+0.03/-0	19.1	0.8	7.9	31.0	203	0.38	11.10
CCFE 11/16 B	CCFE 11/16 SB	17.46	+0/-0.03	11.11	+0 / -0.13	6.35	+0.03/-0	19.1	0.8	7.9	31.0	203	0.38	11.10
CFH 11/16	CFH 11/16 S	17.46	+0/-0.03	11.11	+0 / -0.13	7.94	+0.03/-0	19.1	0.8	7.9	31.0	-	-	-
CFH 11/16 B	CFH 11/16 SB	17.46	+0/-0.03	11.11	+0 / -0.13	7.94	+0.03/-0	19.1	0.8	7.9	31.0	-	-	-
CCFH 11/16	CCFH 11/16 S	17.46	+0/-0.03	11.11	+0 / -0.13	7.94	+0.03/-0	19.1	0.8	7.9	31.0	203	-	-
CCFH 11/16 B	CCFH 11/16 SB	17.46	+0/-0.03	11.11	+0 / -0.13	7.94	+0.03/-0	19.1	0.8	7.9	31.0	203	-	-

BD	Rated load		Mounting dimension						Thread		Tightening torque	Limit speed (grease)	Weight
	Cr	Cor	HC mm	HD	F	E	Ro	Seat hole diameter HBD		WT			
±0.025	N		(Ref)	(Ref)	(Ref)	(Ref)	(Ref)	Nom	Tol	Nm	RPM	kg	
-	4,248	5,404	-	-	3.175	11.73	0.4	6.358	+0.005/-0.008	1/4-28	4	9,200	0.02
-	4,248	5,404	-	-	3.175	11.73	0.4	6.358	+0.005/-0.008	1/4-28	4	9,200	0.02
-	4,248	5,404	-	-	3.175	11.73	N/A	6.358	+0.005/-0.008	1/4-28	4	9,200	0.02
-	4,248	5,404	-	-	3.175	11.73	N/A	6.358	+0.005/-0.008		4	9,200	0.02
9.53	4,248	5,404	-	-	3.175	11.73	0.4	9.60	+0.025/-0.025	1/4-28	10	9,200	0.02
9.53	4,248	5,404	-	-	3.175	11.73	0.4	9.60	+0.025/-0.025	1/4-28	10	9,200	0.02
9.53	4,248	5,404	-	-	3.175	11.73	N/A	9.60	+0.025/-0.025	1/4-28	10	9,200	0.02
9.53	4,248	5,404	-	-	3.175	11.73	N/A	9.60	+0.025/-0.025	1/4-28	10	9,200	0.02
-	4,248	11,031	-	-	3.175	11.73	0.4	7.945	+0.005/-0.008	5/16-24	4	9,200	0.02
-	4,248	11,031	-	-	3.175	11.73	0.4	7.945	+0.005/-0.008	5/16-24	4	9,200	0.02
-	4,248	11,031	-	-	3.175	11.73	N/A	7.945	+0.005/-0.008	5/16-24	4	9,200	0.02
-	4,248	11,031	-	-	3.175	11.73	N/A	7.945	+0.005/-0.008	5/16-24	4	9,200	0.02
-	4,137	4,826	-	-	3.175	11.73	0.4	6.358	+0.005/-0.008	1/4-28	4	9,200	0.02
-	4,137	4,826	-	-	3.175	11.73	0.4	6.358	+0.005/-0.008	1/4-28	4	9,200	0.02
-	4,137	4,826	-	-	3.175	11.73	N/A	6.358	+0.005/-0.008	1/4-28	4	9,200	0.02
-	4,137	4,826	-	-	3.175	11.73	N/A	6.358	+0.005/-0.008	1/4-28	4	9,200	0.02
9.53					3.175	11.73	N/A	6.358	+0.005/-0.008	1/4-28	4	9,200	0.02
-	4,248	5,404	-	-	3.175	11.73	0.4	6.358	+0.005/-0.008	1/4-28	4	8,300	0.03
-	4,248	5,404	-	-	3.175	11.73	0.4	6.358	+0.005/-0.008	1/4-28	4	8,300	0.03
-	4,248	5,404	-	-	3.175	11.73	N/A	6.358	+0.005/-0.008	1/4-28	4	8,300	0.03
-	4,248	5,404	-	-	3.175	11.73	N/A	6.358	+0.005/-0.008	1/4-28	4	8,300	0.03
9.53	4,248	5,404	-	-	3.175	11.73	0.4	9.60	+0.025/-0.025	1/4-28	4	8,300	0.03
9.53	4,248	5,404	-	-	3.175	11.73	0.4	9.60	+0.025/-0.025	1/4-28	4	8,300	0.03
9.53	4,248	5,404	-	-	3.175	11.73	N/A	9.60	+0.025/-0.025	1/4-28	4	8,300	0.03
9.53	4,248	5,404	-	-	3.175	11.73	N/A	9.60	+0.025/-0.025	1/4-28	4	8,300	0.03
-	4,248	11,031	-	-	3.175	11.73	0.4	7.945	+0.005/-0.008	5/16-24	10	8,300	0.03
-	4,248	11,031	-	-	3.175	11.73	0.4	7.945	+0.005/-0.008	5/16-24	10	8,300	0.03
-	4,248	11,031	-	-	3.175	11.73	N/A	7.945	+0.005/-0.008	5/16-24	10	8,300	0.03
-	4,248	11,031	-	-	3.175	11.73	N/A	7.945	+0.005/-0.008	5/16-24	10	8,300	0.03

# Parameter sheet

## CF Inch roller series

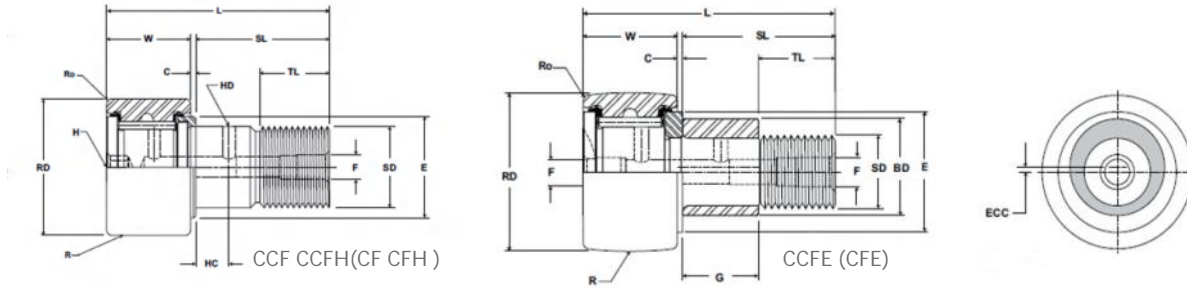

Bearing model		Structure dimension											Eccentric locking collar	
Sealless type	Seal type	RD	W		SD		SL	C	TL	L	R	ECC	G	
		mm	Nom	Tol	Nom	Tol	Nom	Tol	(Ref)	(Ref)	(Ref)	(Ref)	(Ref)	(Ref)
CF 3/4	CF 3/4 S	19.05	+0/-0.03	12.70	+0 / -0.13	9.53	+0.03/-0	22.2	0.8	9.5	35.7	-	-	-
CF 3/4 B	CF 3/4 SB	19.05	+0/-0.03	12.70	+0 / -0.13	9.53	+0.03/-0	22.2	0.8	9.5	35.7	-	-	-
CCF 3/4	CCF 3/4 S	19.05	+0/-0.03	12.70	+0 / -0.13	9.53	+0.03/-0	22.2	0.8	9.5	35.7	254	-	-
CCF 3/4 B	CCF 3/4 SB	19.05	+0/-0.03	12.70	+0 / -0.13	9.53	+0.03/-0	22.2	0.8	9.5	35.7	254	-	-
CFE 3/4	CFE 3/4 S	19.05	+0/-0.03	12.70	+0 / -0.13	9.53	+0.03/-0	22.2	0.8	9.5	35.7	-	0.38	12.70
CFE 3/4 B	CFE 3/4 SB	19.05	+0/-0.03	12.70	+0 / -0.13	9.53	+0.03/-0	22.2	0.8	9.5	35.7	-	0.38	12.70
CCFE 3/4	CCFE 3/4 S	19.05	+0/-0.03	12.70	+0 / -0.13	9.53	+0.03/-0	22.2	0.8	9.5	35.7	254	0.38	12.70
CCFE 3/4 B	CCFE 3/4 SB	19.05	+0/-0.03	12.70	+0 / -0.13	9.53	+0.03/-0	22.2	0.8	9.5	35.7	254	0.38	12.70
CFH 3/4	CFH 3/4 S	19.05	+0/-0.03	12.70	+0 / -0.13	11.11	+0.03/-0	22.2	0.8	9.5	35.7	-	-	-
CFH 3/4 B	CFH 3/4 SB	19.05	+0/-0.03	12.70	+0 / -0.13	11.11	+0.03/-0	22.2	0.8	9.5	35.7	-	-	-
CCFH 3/4	CCFH 3/4 S	19.05	+0/-0.03	12.70	+0 / -0.13	11.11	+0.03/-0	22.2	0.8	9.5	35.7	254	-	-
CCFH 3/4 B	CCFH 3/4 SB	19.05	+0/-0.03	12.70	+0 / -0.13	11.11	+0.03/-0	22.2	0.8	9.5	35.7	254	-	-
CF 7/8	CF 7/8 S	22.23	+0/-0.03	12.70	+0 / -0.13	9.53	+0.03/-0	22.2	0.8	9.5	35.7	-	-	-
CF 7/8 B	CF 7/8 SB	22.23	+0/-0.03	12.70	+0 / -0.13	9.53	+0.03/-0	22.2	0.8	9.5	35.7	-	-	-
CCF 7/8	CCF 7/8 S	22.23	+0/-0.03	12.70	+0 / -0.13	9.53	+0.03/-0	22.2	0.8	9.5	35.7	254	-	-
CCF 7/8 B	CCF 7/8 SB	22.23	+0/-0.03	12.70	+0 / -0.13	9.53	+0.03/-0	22.2	0.8	9.5	35.7	254	-	-
CFE 7/8	CFE 7/8 S	22.23	+0/-0.03	12.70	+0 / -0.13	9.53	+0.03/-0	22.2	0.8	9.5	35.7	-	0.38	12.70
CFE 7/8 B	CFE 7/8 SB	22.23	+0/-0.03	12.70	+0 / -0.13	9.53	+0.03/-0	22.2	0.8	9.5	35.7	-	0.38	12.70
CCFE 7/8	CCFE 7/8 S	22.23	+0/-0.03	12.70	+0 / -0.13	9.53	+0.03/-0	22.2	0.8	9.5	35.7	254	0.38	12.70
CCFE 7/8 B	CCFE 7/8 SB	22.23	+0/-0.03	12.70	+0 / -0.13	9.53	+0.03/-0	22.2	0.8	9.5	35.7	254	0.38	12.70
CFH 7/8	CFH 7/8 S	22.23	+0/-0.03	12.70	+0 / -0.13	11.11	+0.03/-0	22.2	0.8	9.5	35.7	-	-	-
CFH 7/8 B	CFH 7/8 SB	22.23	+0/-0.03	12.70	+0 / -0.13	11.11	+0.03/-0	22.2	0.8	9.5	35.7	-	-	-
CCFH 7/8	CCFH 7/8 S	22.23	+0/-0.03	12.70	+0 / -0.13	11.11	+0.03/-0	22.2	0.8	9.5	35.7	254	-	-
CCFH 7/8 B	CCFH 7/8 SB	22.23	+0/-0.03	12.70	+0 / -0.13	11.11	+0.03/-0	22.2	0.8	9.5	35.7	254	-	-

BD	Rated load		Mounting dimension						Thread		Tightening torque	Limit speed (grease)	Weight WT
	Cr	Cor	HC mm	HD	F	E	Ro	Seat hole diameter HBD					
±0.025	N		(Ref)	(Ref)	(Ref)	(Ref)	(Ref)	Nom	Tol		Nm	RPM	kg
-	7,384	9,185	6	2	5	15.48	0.4	9.533	+0.005/-0.008	3/8-24	11	6400	0.03
-	7,384	9,185	6	2	5	15.48	0.4	9.533	+0.005/-0.008	3/8-24	11	6400	0.03
-	7,384	9,185	6	2	5	15.48	N/A	9.533	+0.005/-0.008	3/8-24	11	6400	0.03
-	7,384	9,185	6	2	5	15.48	N/A	9.533	+0.005/-0.008	3/8-24	11	6400	0.03
12.70	7,384	9,185	6	2	5	15.48	0.4	12.77	+0.025/-0.025	3/8-24	11	6400	0.03
12.70	7,384	9,185	6	2	5	15.48	0.4	12.77	+0.025/-0.025	3/8-24	11	6400	0.03
12.70	7,384	9,185	6	2	5	15.48	N/A	12.77	+0.025/-0.025	3/8-24	11	6400	0.03
12.70	7,384	9,185	6	2	5	15.48	N/A	12.77	+0.025/-0.025	3/8-24	11	6400	0.03
-	7,384	18,370	6	2	5	15.48	0.4	11.120	+0.005/-0.008	7/16-20	28	6400	0.04
-	7,384	18,370	6	2	5	15.48	0.4	11.120	+0.005/-0.008	7/16-20	28	6400	0.04
-	7,384	18,370	6	2	5	15.48	N/A	11.120	+0.005/-0.008	7/16-20	28	6400	0.04
-	7,384	18,370	6	2	5	15.48	N/A	11.120	+0.005/-0.008	7/16-20	28	6400	0.04
-	7,384	9,185	6	2	5	15.48	0.4	9.533	+0.005/-0.008	3/8-24	11	5400	0.04
-	7,384	9,185	6	2	5	15.48	0.4	9.533	+0.005/-0.008	3/8-24	11	5400	0.04
-	7,384	9,185	6	2	5	15.48	N/A	9.533	+0.005/-0.008	3/8-24	11	5400	0.04
-	7,384	9,185	6	2	5	15.48	N/A	9.533	+0.005/-0.008	3/8-24	11	5400	0.04
12.70	7,384	9,185	6	2	5	15.48	0.4	12.77	+0.025/-0.025	3/8-24	11	5400	0.04
12.70	7,384	9,185	6	2	5	15.48	0.4	12.77	+0.025/-0.025	3/8-24	11	5400	0.04
12.70	7,384	9,185	6	2	5	15.48	N/A	12.77	+0.025/-0.025	3/8-24	11	5400	0.04
12.70	7,384	9,185	6	2	5	15.48	N/A	12.77	+0.025/-0.025	3/8-24	11	5400	0.04
-	7,384	18,370	6	2	5	15.48	0.4	11.120	+0.005/-0.008	7/16-20	28	5400	0.05
-	7,384	18,370	6	2	5	15.48	0.4	11.120	+0.005/-0.008	7/16-20	28	5400	0.05
-	7,384	18,370	6	2	5	15.48	N/A	11.120	+0.005/-0.008	7/16-20	28	5400	0.05
-	7,384	18,370	6	2	5	15.48	N/A	11.120	+0.005/-0.008	7/16-20	28	5400	0.05

# Parameter sheet

## CF Inch roller series

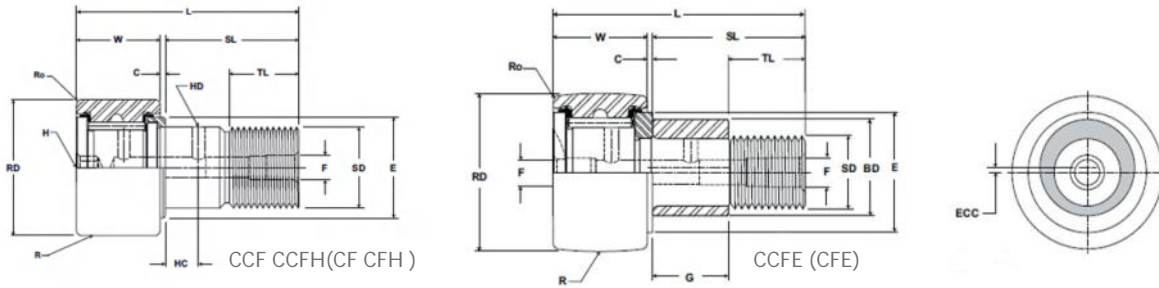

Bearing model		Structure dimension										Eccentric locking collar		
Sealless type	Seal type	RD mm		W		SD		SL	C	TL	L	R	ECC	G
		Nom	Tol	Nom	Tol	Nom	Tol	(Ref)	(Ref)	(Ref)	(Ref)	(Ref)	(Ref)	+0/-0.25
CF 1	CF 1 S	25.40	+0/-0.03	15.88	+0 / -0.13	11.11	+0.03/-0	25.4	0.8	12.7	42.1	-	-	-
CF 1 B	CF 1 SB	25.40	+0/-0.03	15.88	+0 / -0.13	11.11	+0.03/-0	25.4	0.8	12.7	42.1	-	-	-
CCF 1	CCF 1 S	25.40	+0/-0.03	15.88	+0 / -0.13	11.11	+0.03/-0	25.4	0.8	12.7	42.1	305	-	-
CCF 1 B	CCF 1 SB	25.40	+0/-0.03	15.88	+0 / -0.13	11.11	+0.03/-0	25.4	0.8	12.7	42.1	305	-	-
CFE 1	CFE 1 S	25.40	+0/-0.03	15.88	+0 / -0.13	11.11	+0.03/-0	25.4	0.8	12.7	42.1	-	0.76	12.70
CFE 1 B	CFE 1 SB	25.40	+0/-0.03	15.88	+0 / -0.13	11.11	+0.03/-0	25.4	0.8	12.7	42.1	-	0.76	12.70
CCFE 1	CCFE 1 S	25.40	+0/-0.03	15.88	+0 / -0.13	11.11	+0.03/-0	25.4	0.8	12.7	42.1	305	0.76	12.70
CCFE 1 B	CCFE 1 SB	25.40	+0/-0.03	15.88	+0 / -0.13	11.11	+0.03/-0	25.4	0.8	12.7	42.1	305	0.76	12.70
CFH 1	CFH 1 S	25.40	+0/-0.03	15.88	+0 / -0.13	15.88	+0.03/-0	25.4	0.8	12.7	42.1	-	-	-
CFH 1 B	CFH 1 SB	25.40	+0/-0.03	15.88	+0 / -0.13	15.88	+0.03/-0	25.4	0.8	12.7	42.1	-	-	-
CCFH 1	CCFH 1 S	25.40	+0/-0.03	15.88	+0 / -0.13	15.88	+0.03/-0	25.4	0.8	12.7	42.1	305	-	-
CCFH 1 B	CCFH 1 SB	25.40	+0/-0.03	15.88	+0 / -0.13	15.88	+0.03/-0	25.4	0.8	12.7	42.1	305	-	-
CF 1 1/8	CF 1 1/8 S	28.58	+0/-0.03	15.88	+0 / -0.13	11.11	+0.03/-0	25.4	0.8	12.7	0.8	-	-	-
CF 1 1/8 B	CF 1 1/8 SB	28.58	+0/-0.03	15.88	+0 / -0.13	11.11	+0.03/-0	25.4	0.8	12.7	0.8	-	-	-
CCF 1 1/8	CCF 1 1/8 S	28.58	+0/-0.03	15.88	+0 / -0.13	11.11	+0.03/-0	25.4	0.8	12.7	0.8	305	-	-
CCF 1 1/8 B	CCF 1 1/8 SB	28.58	+0/-0.03	15.88	+0 / -0.13	11.11	+0.03/-0	25.4	0.8	12.7	0.8	305	-	-
CFE 1 1/8	CFE 1 1/8 S	28.58	+0/-0.03	15.88	+0 / -0.13	11.11	+0.03/-0	25.4	0.8	12.7	42.1	-	0.76	12.70
CFE 1 1/8 B	CFE 1 1/8 SB	28.58	+0/-0.03	15.88	+0 / -0.13	11.11	+0.03/-0	25.4	0.8	12.7	42.1	-	0.76	12.70
CCFE 1 1/8	CCFE 1 1/8 S	28.58	+0/-0.03	15.88	+0 / -0.13	11.11	+0.03/-0	25.4	0.8	12.7	42.1	305	0.76	12.70
CCFE 1 1/8 B	CCFE 1 1/8 SB	28.58	+0/-0.03	15.88	+0 / -0.13	11.11	+0.03/-0	25.4	0.8	12.7	42.1	305	0.76	12.70
CFH 1 1/8	CFH 1 1/8 S	28.58	+0/-0.03	15.88	+0 / -0.13	15.88	+0.03/-0	25.4	0.8	12.7	42.1	-	-	-
CFH 1 1/8 B	CFH 1 1/8 SB	28.58	+0/-0.03	15.88	+0 / -0.13	15.88	+0.03/-0	25.4	0.8	12.7	42.1	-	-	-
CCFH 1 1/8	CCFH 1 1/8 S	28.58	+0/-0.03	15.88	+0 / -0.13	15.88	+0.03/-0	25.4	0.8	12.7	42.1	305	-	-
CCFH 1 1/8 B	CCFH 1 1/8 SB	28.58	+0/-0.03	15.88	+0 / -0.13	15.88	+0.03/-0	25.4	0.8	12.7	42.1	305	-	-

BD	Rated load		Mounting dimension						Thread		Tightening torque	Limit speed (grease)	Weight
	Cr	Cor	HC mm	HD	F	E	Ro	Seat hole diameter HBD		WT			
±0.025	N		(Ref)	(Ref)	(Ref)	(Ref)	(Ref)	Nom	Tol		Nm	RPM	kg
-	9,897	13,611	6	2	5	19.84	0.79	11.120	+0.005/-0.008	7/16-20	28	4,800	0.08
-	9,897	13,611	6	2	5	19.84	0.79	11.120	+0.005/-0.008	7/16-20	28	4,800	0.08
-	9,897	13,611	6	2	5	19.84	N/A	11.120	+0.005/-0.008	7/16-20	28	4,800	0.08
-	9,897	13,611	6	2	5	19.84	N/A	11.120	+0.005/-0.008	7/16-20	28	4,800	0.08
15.88	9,897	13,611	6	2	5	19.84	0.79	15.95	+0.025/-0.025	7/16-20	28	4,800	0.08
15.88	9,897	13,611	6	2	5	19.84	0.79	15.95	+0.025/-0.025	7/16-20	28	4,800	0.08
15.88	9,897	13,611	6	2	5	19.84	N/A	15.95	+0.025/-0.025	7/16-20	28	4,800	0.08
15.88	9,897	13,611	6	2	5	19.84	N/A	15.95	+0.025/-0.025	7/16-20	28	4,800	0.08
-	9,897	27,222	6	2	5	19.84	0.79	15.883	+0.005/-0.008	5/8-18	73	4,800	0.09
-	9,897	27,222	6	2	5	19.84	0.79	15.883	+0.005/-0.008	5/8-18	73	4,800	0.09
-	9,897	27,222	6	2	5	19.84	N/A	15.883	+0.005/-0.008	5/8-18	73	4,800	0.09
-	9,897	27,222	6	2	5	19.84	N/A	15.883	+0.005/-0.008	5/8-18	73	4,800	0.09
-	9,897	13,611	6	2	5	19.84	0.79	11.120	+0.005/-0.008	7/16-20	28	3,400	0.09
-	9,897	13,611	6	2	5	19.84	0.79	11.120	+0.005/-0.008	7/16-20	28	3,400	0.09
-	9,897	13,611	6	2	5	19.84	N/A	11.120	+0.005/-0.008	7/16-20	28	3,400	0.09
-	9,897	13,611	6	2	5	19.84	N/A	11.120	+0.005/-0.008	7/16-20	28	3,400	0.09
15.88	9,897	13,611	6	2	5	19.84	0.79	15.95	+0.025/-0.025	7/16-20	28	3,400	0.09
15.88	9,897	13,611	6	2	5	19.84	0.79	15.95	+0.025/-0.025	7/16-20	28	3,400	0.09
15.88	9,897	13,611	6	2	5	19.84	N/A	15.95	+0.025/-0.025	7/16-20	28	3,400	0.09
15.88	9,897	13,611	6	2	5	19.84	N/A	15.95	+0.025/-0.025	7/16-20	28	3,400	0.09
-	9,897	27,222	6	2	5	19.84	0.79	15.883	+0.005/-0.008	5/8-18	73	3,400	0.11
-	9,897	27,222	6	2	5	19.84	0.79	15.883	+0.005/-0.008	5/8-18	73	3,400	0.11
-	9,897	27,222	6	2	5	19.84	N/A	15.883	+0.005/-0.008	5/8-18	73	3,400	0.11
-	9,897	27,222	6	2	5	19.84	N/A	15.883	+0.005/-0.008	5/8-18	73	3,400	0.11

# Parameter sheet

## CF Inch roller series

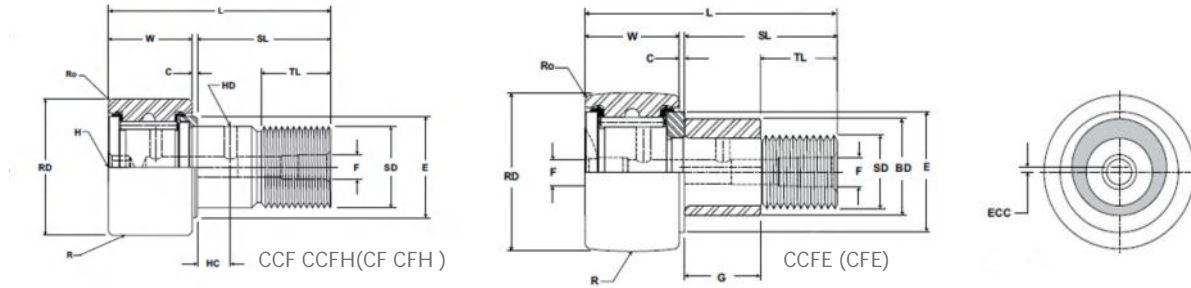

Bearing model		Structure dimension										Eccentric locking collar		
Sealless type	Seal type	RD	W		SD		SL	C	TL	L	R	ECC	G	
		mm	Nom	Tol	Nom	Tol	Nom	Tol	(Ref)	(Ref)	(Ref)	(Ref)	(Ref)	(Ref)
CF 1 1/4	CF 1 1/4 S	31.75	+0/-0.03	19.05	+0 / -0.13	12.70	+0.03/-0	31.8	0.8	15.9	51.6	-	-	-
CF 1 1/4 B	CF 1 1/4 SB	31.75	+0/-0.03	19.05	+0 / -0.13	12.70	+0.03/-0	31.8	0.8	15.9	51.6	-	-	-
CCF 1 1/4	CCF 1 1/4 S	31.75	+0/-0.03	19.05	+0 / -0.13	12.70	+0.03/-0	31.8	0.8	15.9	51.6	356	-	-
CCF 1 1/4 B	CCF 1 1/4 SB	31.75	+0/-0.03	19.05	+0 / -0.13	12.70	+0.03/-0	31.8	0.8	15.9	51.6	356	-	-
CFE 1 1/4	CFE 1 1/4 S	31.75	+0/-0.03	19.05	+0 / -0.13	12.70	+0.03/-0	31.8	0.8	15.9	51.6	-	0.76	15.88
CFE 1 1/4 B	CFE 1 1/4 SB	31.75	+0/-0.03	19.05	+0 / -0.13	12.70	+0.03/-0	31.8	0.8	15.9	51.6	-	0.76	15.88
CCFE 1 1/4	CCFE 1 1/4 S	31.75	+0/-0.03	19.05	+0 / -0.13	12.70	+0.03/-0	31.8	0.8	15.9	51.6	356	0.76	15.88
CCFE 1 1/4 B	CCFE 1 1/4 SB	31.75	+0/-0.03	19.05	+0 / -0.13	12.70	+0.03/-0	31.8	0.8	15.9	51.6	356	0.76	15.88
CFH 1 1/4	CFH 1 1/4 S	31.75	+0/-0.03	19.05	+0 / -0.13	12.70	+0.03/-0	31.8	0.8	15.9	51.6	-	-	-
CFH 1 1/4 B	CFH 1 1/4 SB	31.75	+0/-0.03	19.05	+0 / -0.13	12.70	+0.03/-0	31.8	0.8	15.9	51.6	-	-	-
CCFH 1 1/4	CCFH 1 1/4 S	31.75	+0/-0.03	19.05	+0 / -0.13	12.70	+0.03/-0	31.8	0.8	15.9	51.6	356	-	-
CCFH 1 1/4 B	CCFH 1 1/4 SB	31.75	+0/-0.03	19.05	+0 / -0.13	12.70	+0.03/-0	31.8	0.8	15.9	51.6	356	-	-
CF 1 3/8	CF 1 3/8 S	34.93	+0/-0.03	19.05	+0 / -0.13	12.70	+0.03/-0	31.8	0.8	15.9	51.6	-	-	-
CF 1 3/8 B	CF 1 3/8 SB	34.93	+0/-0.03	19.05	+0 / -0.13	12.70	+0.03/-0	31.8	0.8	15.9	51.6	-	-	-
CCF 1 3/8	CCF 1 3/8 S	34.93	+0/-0.03	19.05	+0 / -0.13	12.70	+0.03/-0	31.8	0.8	15.9	51.6	356	-	-
CCF 1 3/8 B	CCF 1 3/8 SB	34.93	+0/-0.03	19.05	+0 / -0.13	12.70	+0.03/-0	31.8	0.8	15.9	51.6	356	-	-
CFE 1 3/8	CFE 1 3/8 S	34.93	+0/-0.03	19.05	+0 / -0.13	12.70	+0.03/-0	31.8	0.8	15.9	51.6	-	0.76	15.88
CFE 1 3/8 B	CFE 1 3/8 SB	34.93	+0/-0.03	19.05	+0 / -0.13	12.70	+0.03/-0	31.8	0.8	15.9	51.6	-	0.76	15.88
CCFE 1 3/8	CCFE 1 3/8 S	34.93	+0/-0.03	19.05	+0 / -0.13	12.70	+0.03/-0	31.8	0.8	15.9	51.6	356	0.76	15.88
CCFE 1 3/8 B	CCFE 1 3/8 SB	34.93	+0/-0.03	19.05	+0 / -0.13	12.70	+0.03/-0	31.8	0.8	15.9	51.6	356	0.76	15.88
CFH 1 3/8	CFH 1 3/8 S	34.93	+0/-0.03	19.05	+0 / -0.13	12.70	+0.03/-0	31.8	0.8	15.9	51.6	-	-	-
CFH 1 3/8 B	CFH 1 3/8 SB	34.93	+0/-0.03	19.05	+0 / -0.13	12.70	+0.03/-0	31.8	0.8	15.9	51.6	-	-	-
CCFH 1 3/8	CCFH 1 3/8 S	34.93	+0/-0.03	19.05	+0 / -0.13	12.70	+0.03/-0	31.8	0.8	15.9	51.6	356	-	-
CCFH 1 3/8 B	CCFH 1 3/8 SB	34.93	+0/-0.03	19.05	+0 / -0.13	12.70	+0.03/-0	31.8	0.8	15.9	51.6	356	-	-

BD	Rated load		Mounting dimension					Thread		Tightening torque	Limit speed (grease)	Weight WT	
	Cr	Cor	HC mm	HD	F	E	Ro	Seat hole diameter HBD					
±0.025	N		(Ref)	(Ref)	(Ref)	(Ref)	(Ref)	Nom Tol		Nm	RPM	kg	
-	17,481	18,904	8	2	5	25	0.79	12.708	+0.005/-0.008	1/2-20	40	3,100	0.14
-	17,481	18,904	8	2	5	25	0.79	12.708	+0.005/-0.008	1/2-20	40	3,100	0.14
-	17,481	18,904	8	2	5	25	N/A	12.708	+0.005/-0.008	1/2-20	40	3,100	0.14
-	17,481	18,904	8	2	5	25	N/A	12.708	+0.005/-0.008	1/2-20	40	3,100	0.14
17.45	17,481	18,904	8	2	5	25	0.79	17.52	+0.025/-0.025	1/2-20	40	3,100	0.14
17.45	17,481	18,904	8	2	5	25	0.79	17.52	+0.025/-0.025	1/2-20	40	3,100	0.14
17.45	17,481	18,904	8	2	5	25	N/A	17.52	+0.025/-0.025	1/2-20	40	3,100	0.14
17.45	17,481	18,904	8	2	5	25	N/A	17.52	+0.025/-0.025	1/2-20	40	3,100	0.14
-	17,481	37,808	8	2	5	25	0.79	19.058	+0.005/-0.008	3/4-16	141	3,100	0.17
-	17,481	37,808	8	2	5	25	0.79	19.058	+0.005/-0.008	3/4-16	141	3,100	0.17
-	17,481	37,808	8	2	5	25	N/A	19.058	+0.005/-0.008	3/4-16	141	3,100	0.17
-	17,481	37,808	8	2	5	25	N/A	19.058	+0.005/-0.008	3/4-16	141	3,100	0.17
-	17,481	18,904	8	2	5	25	1.19	12.708	+0.005/-0.008	1/2-20	40	2,800	0.16
-	17,481	18,904	8	2	5	25	1.19	12.708	+0.005/-0.008	1/2-20	40	2,800	0.16
-	17,481	18,904	8	2	5	25	N/A	12.708	+0.005/-0.008	1/2-20	40	2,800	0.16
-	17,481	18,904	8	2	5	25	N/A	12.708	+0.005/-0.008	1/2-20	40	2,800	0.16
17.45	17,481	18,904	8	2	5	25	1.19	17.52	+0.025/-0.025	1/2-20	40	2,800	0.16
17.45	17,481	18,904	8	2	5	25	1.19	17.52	+0.025/-0.025	1/2-20	40	2,800	0.16
17.45	17,481	18,904	8	2	5	25	N/A	17.52	+0.025/-0.025	1/2-20	40	2,800	0.16
17.45	17,481	18,904	8	2	5	25	N/A	17.52	+0.025/-0.025	1/2-20	40	2,800	0.16
-	17,481	37,808	8	2	5	25	1.19	19.058	+0.005/-0.008	3/4-16	141	2,800	0.19
-	17,481	37,808	8	2	5	25	1.19	19.058	+0.005/-0.008	3/4-16	141	2,800	0.19
-	17,481	37,808	8	2	5	25	N/A	19.058	+0.005/-0.008	3/4-16	141	2,800	0.19
-	17,481	37,808	8	2	5	25	N/A	19.058	+0.005/-0.008	3/4-16	141	2,800	0.19

# Parameter sheet

## CF Inch roller series

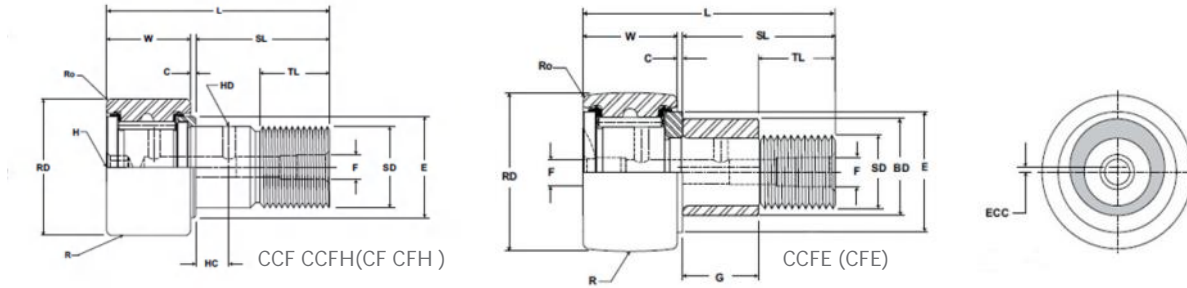

Bearing model		Structure dimension										Eccentric locking collar		
Sealless type	Seal type	RD	W		SD		SL	C	TL	L	R	ECC	G	
		mm	Nom	Tol	Nom	Tol	Nom	Tol	(Ref)	(Ref)	(Ref)	(Ref)	(Ref)	+0/-0.25
CF 1 1/2	CF 1 1/2 S	38.10	+0/-0.03	22.23	+0 / -0.13	15.88	+0.03/-0	38.1	0.8	19.1	61.1	-	-	-
CF 1 1/2 B	CF 1 1/2 SB	38.10	+0/-0.03	22.23	+0 / -0.13	15.88	+0.03/-0	38.1	0.8	19.1	61.1	-	-	-
CCF 1 1/2	CCF 1 1/2 S	38.10	+0/-0.03	22.23	+0 / -0.13	15.88	+0.03/-0	38.1	0.8	19.1	61.1	508	-	-
CCF 1 1/2 B	CCF 1 1/2 SB	38.10	+0/-0.03	22.23	+0 / -0.13	15.88	+0.03/-0	38.1	0.8	19.1	61.1	508	-	-
CFE 1 1/2	CFE 1 1/2 S	38.10	+0/-0.03	22.23	+0 / -0.13	15.88	+0.03/-0	38.1	0.8	19.1	61.1	-	0.76	19.05
CFE 1 1/2 B	CFE 1 1/2 SB	38.10	+0/-0.03	22.23	+0 / -0.13	15.88	+0.03/-0	38.1	0.8	19.1	61.1	-	0.76	19.05
CCFE 1 1/2	CCFE 1 1/2 S	38.10	+0/-0.03	22.23	+0 / -0.13	15.88	+0.03/-0	38.1	0.8	19.1	61.1	508	0.76	19.05
CCFE 1 1/2 B	CCFE 1 1/2 SB	38.10	+0/-0.03	22.23	+0 / -0.13	15.88	+0.03/-0	38.1	0.8	19.1	61.1	508	0.76	19.05
CFH 1 1/2	CFH 1 1/2 S	38.10	+0/-0.03	22.23	+0 / -0.13	22.23	+0.03/-0	38.1	0.8	19.1	61.1	-	-	-
CFH 1 1/2 B	CFH 1 1/2 SB	38.10	+0/-0.03	22.23	+0 / -0.13	22.23	+0.03/-0	38.1	0.8	19.1	61.1	-	-	-
CCFH 1 1/2	CCFH 1 1/2 S	38.10	+0/-0.03	22.23	+0 / -0.13	22.23	+0.03/-0	38.1	0.8	19.1	61.1	508	-	-
CCFH 1 1/2 B	CCFH 1 1/2 SB	38.10	+0/-0.03	22.23	+0 / -0.13	22.23	+0.03/-0	38.1	0.8	19.1	61.1	508	-	-
CF 1 5/8	CF 1 5/8 S	41.28	+0/-0.03	22.23	+0 / -0.13	15.88	+0.03/-0	38.1	0.8	19.1	61.1	-	-	-
CF 1 5/8 B	CF 1 5/8 SB	41.28	+0/-0.03	22.23	+0 / -0.13	15.88	+0.03/-0	38.1	0.8	19.1	61.1	-	-	-
CCF 1 5/8	CCF 1 5/8 S	41.28	+0/-0.03	22.23	+0 / -0.13	15.88	+0.03/-0	38.1	0.8	19.1	61.1	508	-	-
CCF 1 5/8 B	CCF 1 5/8 SB	41.28	+0/-0.03	22.23	+0 / -0.13	15.88	+0.03/-0	38.1	0.8	19.1	61.1	508	-	-
CFE 1 5/8	CFE 1 5/8 S	41.28	+0/-0.03	22.23	+0 / -0.13	15.88	+0.03/-0	38.1	0.8	19.1	61.1	-	0.76	19.05
CFE 1 5/8 B	CFE 1 5/8 SB	41.28	+0/-0.03	22.23	+0 / -0.13	15.88	+0.03/-0	38.1	0.8	19.1	61.1	-	0.76	19.05
CCFE 1 5/8	CCFE 1 5/8 S	41.28	+0/-0.03	22.23	+0 / -0.13	15.88	+0.03/-0	38.1	0.8	19.1	61.1	508	0.76	19.05
CCFE 1 5/8 B	CCFE 1 5/8 SB	41.28	+0/-0.03	22.23	+0 / -0.13	15.88	+0.03/-0	38.1	0.8	19.1	61.1	508	0.76	19.05
CFH 1 5/8	CFH 1 5/8 S	41.28	+0/-0.03	22.23	+0 / -0.13	22.23	+0.03/-0	38.1	0.8	19.1	61.1	-	-	-
CFH 1 5/8 B	CFH 1 5/8 SB	41.28	+0/-0.03	22.23	+0 / -0.13	22.23	+0.03/-0	38.1	0.8	19.1	61.1	-	-	-
CCFH 1 5/8	CCFH 1 5/8 S	41.28	+0/-0.03	22.23	+0 / -0.13	22.23	+0.03/-0	38.1	0.8	19.1	61.1	508	-	-
CCFH 1 5/8 B	CCFH 1 5/8 SB	41.28	+0/-0.03	22.23	+0 / -0.13	22.23	+0.03/-0	38.1	0.8	19.1	61.1	508	-	-

BD	Rated load		Mounting dimension						Thread		Tightening torque	Limit speed (grease)	Weight WT
	Cr	Cor	HC mm	HD	F	E	Ro	Seat hole diameter HBD					
±0.025	N		(Ref)	(Ref)	(Ref)	(Ref)	(Ref)	Nom	Tol		Nm	RPM	kg
-	21,528	25,087	10	2	5	27.78	1.59	15.883	+0.005/-0.008	5/8-18	73	2,500	0.24
-	21,528	25,087	10	2	5	27.78	1.59	15.883	+0.005/-0.008	5/8-18	73	2,500	0.24
-	21,528	25,087	10	2	5	27.78	N/A	15.883	+0.005/-0.008	5/8-18	73	2,500	0.24
-	21,528	25,087	10	2	5	27.78	N/A	15.883	+0.005/-0.008	5/8-18	73	2,500	0.24
22.23	21,528	25,087	10	2	5	27.78	1.59	22.30	+0.025/-0.025	5/8-18	73	2,500	0.24
22.23	21,528	25,087	10	2	5	27.78	1.59	22.30	+0.025/-0.025	5/8-18	73	2,500	0.24
22.23	21,528	25,087	10	2	5	27.78	N/A	22.30	+0.025/-0.025	5/8-18	73	2,500	0.24
22.23	21,528	25,087	10	2	5	27.78	N/A	22.30	+0.025/-0.025	5/8-18	73	2,500	0.24
-	21,528	50,173	10	2	5	27.78	1.59	22.233	+0.005/-0.008	7/8-14	170	2,500	0.31
-	21,528	50,173	10	2	5	27.78	1.59	22.233	+0.005/-0.008	7/8-14	170	2,500	0.31
-	21,528	50,173	10	2	5	27.78	N/A	22.233	+0.005/-0.008	7/8-14	170	2,500	0.31
-	21,528	50,173	10	2	5	27.78	N/A	22.233	+0.005/-0.008	7/8-14	170	2,500	0.31
-	21,528	25087	10	2	5	27.78	1.59	15.883	+0.005/-0.008	5/8-18	73	2,350	0.27
-	21,528	25,087	10	2	5	27.78	1.59	15.883	+0.005/-0.008	5/8-18	73	2,350	0.27
-	21,528	25,087	10	2	5	27.78	N/A	15.883	+0.005/-0.008	5/8-18	73	2,350	0.27
-	21,528	25,087	10	2	5	27.78	N/A	15.883	+0.005/-0.008	5/8-18	73	2,350	0.27
22.23	21,528	25,087	10	2	5	27.78	1.59	22.30	+0.025/-0.025	5/8-18	73	2,350	0.27
22.23	21,528	25,087	10	2	5	27.78	1.59	22.30	+0.025/-0.025	5/8-18	73	2,350	0.27
22.23	21,528	25,087	10	2	5	27.78	N/A	22.30	+0.025/-0.025	5/8-18	73	2,350	0.27
22.23	21,528	25,087	10	2	5	27.78	N/A	22.30	+0.025/-0.025	5/8-18	73	2,350	0.27
-	21,528	50,173	10	2	5	27.78	1.59	22.233	+0.005/-0.008	7/8-14	170	2,350	0.34
-	21,528	50,173	10	2	5	27.78	1.59	22.233	+0.005/-0.008	7/8-14	170	2,350	0.34
-	21,528	50,173	10	2	5	27.78	N/A	22.233	+0.005/-0.008	7/8-14	170	2,350	0.34
-	21,528	50,173	10	2	5	27.78	N/A	22.233	+0.005/-0.008	7/8-14	170	2,350	0.34

# Parameter sheet

## CF Inch roller series

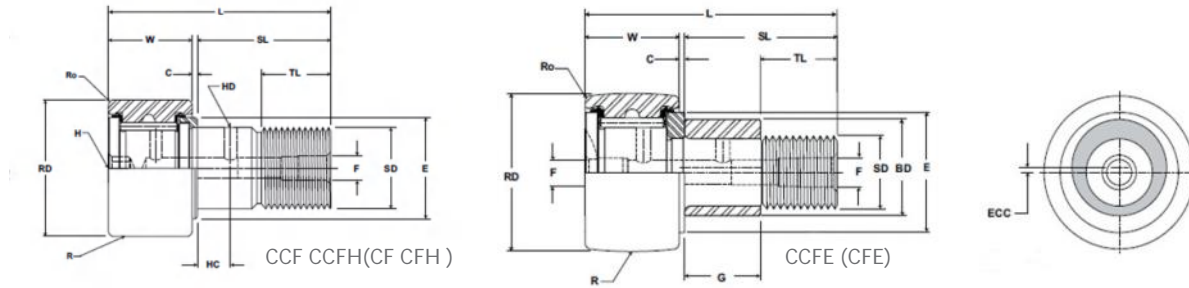

Bearing model		Structure dimension										Eccentric locking collar		
Sealless type	Seal type	RD	W		SD		SL	C	TL	L	R	ECC	G	
		mm	Nom	Tol	Nom	Tol	Nom	Tol	(Ref)	(Ref)	(Ref)	(Ref)	(Ref)	+0/-0.25
CF 1 3/4	CF 1 3/4 S	44.45	+0/-0.03	25.40	+0 / -0.13	19.05	+0.03/-0	44.5	0.8	22.2	70.6	-	-	-
CF 1 3/4 B	CF 1 3/4 SB	44.45	+0/-0.03	25.40	+0 / -0.13	19.05	+0.03/-0	44.5	0.8	22.2	70.6	-	-	-
CCF 1 3/4	CCF 1 3/4 S	44.45	+0/-0.03	25.40	+0 / -0.13	19.05	+0.03/-0	44.5	0.8	22.2	70.6	508	-	-
CCF 1 3/4 B	CCF 1 3/4 SB	44.45	+0/-0.03	25.40	+0 / -0.13	19.05	+0.03/-0	44.5	0.8	22.2	70.6	508	-	-
CFE 1 3/4	CFE 1 3/4 S	44.45	+0/-0.03	25.40	+0 / -0.13	19.05	+0.03/-0	44.5	0.8	22.2	70.6	-	0.76	22.23
CFE 1 3/4 B	CFE 1 3/4 SB	44.45	+0/-0.03	25.40	+0 / -0.13	19.05	+0.03/-0	44.5	0.8	22.2	70.6	-	0.76	22.23
CCFE 1 3/4	CCFE 1 3/4 S	44.45	+0/-0.03	25.40	+0 / -0.13	19.05	+0.03/-0	44.5	0.8	22.2	70.6	508	0.76	22.23
CCFE 1 3/4 B	CCFE 1 3/4 SB	44.45	+0/-0.03	25.40	+0 / -0.13	19.05	+0.03/-0	44.5	0.8	22.2	70.6	508	0.76	22.23
CFH 1 3/4	CFH 1 3/4 S	44.45	+0/-0.03	25.40	+0 / -0.13	25.40	+0.03/-0	44.5	0.8	22.2	70.6	-	-	-
CFH 1 3/4 B	CFH 1 3/4 SB	44.45	+0/-0.03	25.40	+0 / -0.13	25.40	+0.03/-0	44.5	0.8	22.2	70.6	-	-	-
CCFH 1 3/4	CCFH 1 3/4 S	44.45	+0/-0.03	25.40	+0 / -0.13	25.40	+0.03/-0	44.5	0.8	22.2	70.6	508	-	-
CCFH 1 3/4 B	CCFH 1 3/4 SB	44.45	+0/-0.03	25.40	+0 / -0.13	25.40	+0.03/-0	44.5	0.8	22.2	70.6	508	-	-
CF 1 7/8	CF 1 7/8 S	47.63	+0/-0.03	25.40	+0 / -0.13	19.05	+0.03/-0	44.5	0.8	22.2	70.6	-	-	-
CF 1 7/8 B	CF 1 7/8 SB	47.63	+0/-0.03	25.40	+0 / -0.13	19.05	+0.03/-0	44.5	0.8	22.2	70.6	-	-	-
CCF 1 7/8	CCF 1 7/8 S	47.63	+0/-0.03	25.40	+0 / -0.13	19.05	+0.03/-0	44.5	0.8	22.2	70.6	508	-	-
CCF 1 7/8 B	CCF 1 7/8 SB	47.63	+0/-0.03	25.40	+0 / -0.13	19.05	+0.03/-0	44.5	0.8	22.2	70.6	508	-	-
CFE 1 7/8	CFE 1 7/8 S	47.63	+0/-0.03	25.40	+0 / -0.13	19.05	+0.03/-0	44.5	0.8	22.2	70.6	-	0.76	22.24
CFE 1 7/8 B	CFE 1 7/8 SB	47.63	+0/-0.03	25.40	+0 / -0.13	19.05	+0.03/-0	44.5	0.8	22.2	70.6	-	0.76	22.24
CCFE 1 7/8	CCFE 1 7/8 S	47.63	+0/-0.03	25.40	+0 / -0.13	19.05	+0.03/-0	44.5	0.8	22.2	70.6	508	0.76	22.24
CCFE 1 7/8 B	CCFE 1 7/8 SB	47.63	+0/-0.03	25.40	+0 / -0.13	19.05	+0.03/-0	44.5	0.8	22.2	70.6	508	0.76	22.24
CFH 1 7/8	CFH 1 7/8 S	47.63	+0/-0.03	25.40	+0 / -0.13	25.40	+0.03/-0	44.5	0.8	22.2	70.6	-	-	-
CFH 1 7/8 B	CFH 1 7/8 SB	47.63	+0/-0.03	25.40	+0 / -0.13	25.40	+0.03/-0	44.5	0.8	22.2	70.6	-	-	-
CCFH 1 7/8	CCFH 1 7/8 S	47.63	+0/-0.03	25.40	+0 / -0.13	25.40	+0.03/-0	44.5	0.8	22.2	70.6	508	-	-
CCFH 1 7/8 B	CCFH 1 7/8 SB	47.63	+0/-0.03	25.40	+0 / -0.13	25.40	+0.03/-0	44.5	0.8	22.2	70.6	508	-	-

BD	Rated load		Mounting dimension						Thread		Tightening torque	Limit speed (grease)	Weight WT
	Cr	Cor	HC mm	HD	F	E	Ro	Seat hole diameter HBD					
±0.025	N		(Ref)	(Ref)	(Ref)	(Ref)	(Ref)	Nom	Tol		Nm	RPM	kg
-	28,400	35,228	11	3	5	31.75	1.59	19.058	+0.005/-0.008	3/4-16	141	2,200	0.38
-	28,400	35,228	11	3	5	31.75	1.59	19.058	+0.005/-0.008	3/4-16	141	2,200	0.38
-	28,400	35,228	11	3	5	31.75	N/A	19.058	+0.005/-0.008	3/4-16	141	2,200	0.38
-	28,400	35,228	11	3	5	31.75	N/A	19.058	+0.005/-0.008	3/4-16	141	2,200	0.38
25.40	28,400	35,228	11	3	5	31.75	1.59	25.47	+0.025/-0.025	3/4-16	141	2,200	0.38
25.40	28,400	35,228	11	3	5	31.75	1.59	25.47	+0.025/-0.025	3/4-16	141	2,200	0.38
25.40	28,400	35,228	11	3	5	31.75	N/A	25.47	+0.025/-0.025	3/4-16	141	2,200	0.38
25.40	28,400	35,228	11	3	5	31.75	N/A	25.47	+0.025/-0.025	3/4-16	141	2,200	0.38
-	28,400	70,456	11	3	5	31.75	1.59	25.408	+0.005/-0.008	1-14	254	2,200	0.45
-	28,400	70,456	11	3	5	31.75	1.59	25.408	+0.005/-0.008	1-14	254	2,200	0.45
-	28,400	70,456	11	3	5	31.75	N/A	25.408	+0.005/-0.008	1-14	254	2,200	0.45
-	28,400	70,456	11	3	5	31.75	N/A	25.408	+0.005/-0.008	1-14	254	2,200	0.45
-	28,400	35,228	11	3	5	31.75	1.59	19.058	+0.005/-0.008	3/4-16	141	2,000	0.43
-	28,400	35,228	11	3	5	31.75	1.59	19.058	+0.005/-0.008	3/4-16	141	2,000	0.43
-	28,400	35,228	11	3	5	31.75	N/A	19.058	+0.005/-0.008	3/4-16	141	2,000	0.43
-	28,400	35,228	11	3	5	31.75	N/A	19.058	+0.005/-0.008	3/4-16	141	2,000	0.43
25.40	28,400	35,228	11	3	5	31.75	1.59	25.47	+0.025/-0.025	3/4-16	141	2,000	0.43
25.40	28,400	35,228	11	3	5	31.75	1.59	25.47	+0.025/-0.025	3/4-16	141	2,000	0.43
25.40	28,400	35,228	11	3	5	31.75	N/A	25.47	+0.025/-0.025	3/4-16	141	2,000	0.43
25.40	28,400	35,228	11	3	5	31.75	N/A	25.47	+0.025/-0.025	3/4-16	141	2,000	0.43
-	28,400	70,456	11	3	5	31.75	1.59	25.408	+0.005/-0.008	1-14	254	2,000	0.52
-	28,400	70,456	11	3	5	31.75	1.59	25.408	+0.005/-0.008	1-14	254	2,000	0.52
-	28,400	70,456	11	3	5	31.75	N/A	25.408	+0.005/-0.008	1-14	254	2,000	0.52
-	28,400	70,456	11	3	5	31.75	N/A	25.408	+0.005/-0.008	1-14	254	2,000	0.52

# Parameter sheet

## CF Inch roller series

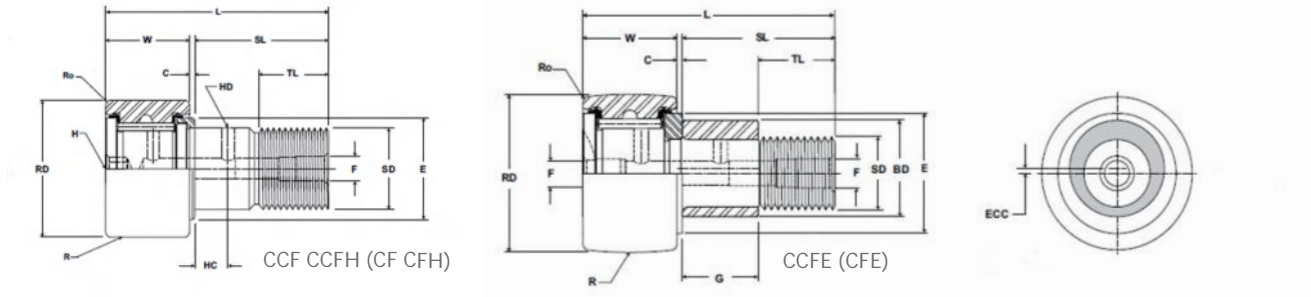

Bearing model		Structure dimension										Eccentric locking collar	
Sealless type	Seal type	RD	W		SD		SL	C	TL	L	R	ECC	G
		mm	Nom	Tol	Nom	Tol	Nom	Tol	(Ref)	(Ref)	(Ref)	(Ref)	(Ref)
CF 2	CF 2 S	50.80 +0/-0.03	31.75 +0 / -0.13	22.23 +0.03/-0	50.8	0.8	25.4	83.3	-	-	-	-	-
CF 2 B	CF 2 SB	50.80 +0/-0.03	31.75 +0 / -0.13	22.23 +0.03/-0	50.8	0.8	25.4	83.3	-	-	-	-	-
CCF 2	CCF 2 S	50.80 +0/-0.03	31.75 +0 / -0.13	22.23 +0.03/-0	50.8	0.8	25.4	83.3	610	-	-	-	-
CCF 2 B	CCF 2 SB	50.80 +0/-0.03	31.75 +0 / -0.13	22.23 +0.03/-0	50.8	0.8	25.4	83.3	610	-	-	-	-
CFE 2	CFE 2 S	50.80 +0/-0.03	31.75 +0 / -0.13	22.23 +0.03/-0	50.8	0.8	25.4	83.3	-	0.76	25.40	-	-
CFE 2 B	CFE 2 SB	50.80 +0/-0.03	31.75 +0 / -0.13	22.23 +0.03/-0	50.8	0.8	25.4	83.3	-	0.76	25.40	-	-
CCFE 2	CCFE 2 S	50.80 +0/-0.03	31.75 +0 / -0.13	22.23 +0.03/-0	50.8	0.8	25.4	83.3	610	0.76	25.40	-	-
CCFE 2 B	CCFE 2 SB	50.80 +0/-0.03	31.75 +0 / -0.13	22.23 +0.03/-0	50.8	0.8	25.4	83.3	610	0.76	25.40	-	-
CFH 2	CFH 2 S	50.80 +0/-0.03	31.75 +0 / -0.13	28.58 +0.03/-0	50.8	0.8	25.4	83.3	-	-	-	-	-
CFH 2 B	CFH 2 SB	50.80 +0/-0.03	31.75 +0 / -0.13	28.58 +0.03/-0	50.8	0.8	25.4	83.3	-	-	-	-	-
CCFH 2	CCFH 2 S	50.80 +0/-0.03	31.75 +0 / -0.13	28.58 +0.03/-0	50.8	0.8	25.4	83.3	610	-	-	-	-
CCFH 2 B	CCFH 2 SB	50.80 +0/-0.03	31.75 +0 / -0.13	28.58 +0.03/-0	50.8	0.8	25.4	83.3	610	-	-	-	-
CF 2 1/4	CF 2 1/4 S	57.15 +0/-0.03	31.75 +0 / -0.13	22.23 +0.03/-0	50.8	0.8	25.4	83.3	-	-	-	-	-
CF 2 1/4 B	CF 2 1/4 SB	57.15 +0/-0.03	31.75 +0 / -0.13	22.23 +0.03/-0	50.8	0.8	25.4	83.3	-	-	-	-	-
CCF 2 1/4	CCF 2 1/4 S	57.15 +0/-0.03	31.75 +0 / -0.13	22.23 +0.03/-0	50.8	0.8	25.4	83.3	610	-	-	-	-
CCF 2 1/4 B	CCF 2 1/4 SB	57.15 +0/-0.03	31.75 +0 / -0.13	22.23 +0.03/-0	50.8	0.8	25.4	83.3	610	-	-	-	-
CFE 2 1/4	CFE 2 1/4 S	57.15 +0/-0.03	31.75 +0 / -0.13	22.23 +0.03/-0	50.8	0.8	25.4	83.3	-	0.76	25.40	-	-
CFE 2 1/4 B	CFE 2 1/4 SB	57.15 +0/-0.03	31.75 +0 / -0.13	22.23 +0.03/-0	50.8	0.8	25.4	83.3	-	0.76	25.40	-	-
CCFE 2 1/4	CCFE 2 1/4 S	57.15 +0/-0.03	31.75 +0 / -0.13	22.23 +0.03/-0	50.8	0.8	25.4	83.3	610	0.76	25.40	-	-
CCFE 2 1/4 B	CCFE 2 1/4 SB	57.15 +0/-0.03	31.75 +0 / -0.13	22.23 +0.03/-0	50.8	0.8	25.4	83.3	610	0.76	25.40	-	-
CFH 2 1/4	CFH 2 1/4 S	57.15 +0/-0.03	31.75 +0 / -0.13	28.58 +0.03/-0	50.8	0.8	25.4	83.3	-	-	-	-	-
CFH 2 1/4 B	CFH 2 1/4 SB	57.15 +0/-0.03	31.75 +0 / -0.13	28.58 +0.03/-0	50.8	0.8	25.4	83.3	-	-	-	-	-
CCFH 2 1/4	CCFH 2 1/4 S	57.15 +0/-0.03	31.75 +0 / -0.13	28.58 +0.03/-0	50.8	0.8	25.4	83.3	610	-	-	-	-
CCFH 2 1/4 B	CCFH 2 1/4 SB	57.15 +0/-0.03	31.75 +0 / -0.13	28.58 +0.03/-0	50.8	0.8	25.4	83.3	610	-	-	-	-

BD	Rated load		Mounting dimension						Thread		Tightening torque	Limit speed (grease)	Weight WT
	Cr	Cor	HC mm	HD	F	E	Ro	Seat hole diameter HBD					
±0.025	N		(Ref)	(Ref)	(Ref)	(Ref)	(Ref)	Nom	Tol		Nm	RPM	kg
-	35,984	47,015	13	3	5	35.72	2.38	22.233	+0.005/-0.008	7/8-14	170	1,400	0.62
-	35,984	47,015	13	3	5	35.72	2.38	22.233	+0.005/-0.008	7/8-14	170	1,400	0.62
-	35,984	47,015	13	3	5	35.72	N/A	22.233	+0.005/-0.008	7/8-14	170	1,400	0.62
-	35,984	47,015	13	3	5	35.72	N/A	22.233	+0.005/-0.008	7/8-14	170	1,400	0.62
30.15	35,984	47,015	13	3	5	35.72	2.38	30.22	+0.025/-0.025	7/8-14	170	1,400	0.62
30.15	35,984	47,015	13	3	5	35.72	2.38	30.22	+0.025/-0.025	7/8-14	170	1,400	0.62
30.15	35,984	47,015	13	3	5	35.72	N/A	30.22	+0.025/-0.025	7/8-14	170	1,400	0.62
30.15	35,984	47,015	13	3	5	35.72	N/A	30.22	+0.025/-0.025	7/8-14	170	1,400	0.62
-	35,984	94,031	13	3	5	35.72	2.38	28.583	+0.005/-0.008	1 1/8-12	316	1,400	0.71
-	35,984	94,031	13	3	5	35.72	2.38	28.583	+0.005/-0.008	1 1/8-12	316	1,400	0.71
-	35,984	94,031	13	3	5	35.72	N/A	28.583	+0.005/-0.008	1 1/8-12	316	1,400	0.71
-	35,984	94,031	13	3	5	35.72	N/A	28.583	+0.005/-0.008	1 1/8-12	316	1,400	0.71
-	35,984	47,015	13	3	5	35.72	2.38	22.233	+0.005/-0.008	7/8-14	170	1,300	0.75
-	35,984	47,015	13	3	5	35.72	2.38	22.233	+0.005/-0.008	7/8-14	170	1,300	0.75
-	35,984	47,015	13	3	5	35.72	N/A	22.233	+0.005/-0.008	7/8-14	170	1,300	0.75
-	35,984	47,015	13	3	5	35.72	N/A	22.233	+0.005/-0.008	7/8-14	170	1,300	0.75
30.15	35,984	47,015	13	3	5	35.72	2.38	30.22	+0.025/-0.025	7/8-14	170	1,300	0.75
30.15	35,984	47,015	13	3	5	35.72	2.38	30.22	+0.025/-0.025	7/8-14	170	1,300	0.75
30.15	35,984	47,015	13	3	5	35.72	N/A	30.22	+0.025/-0.025	7/8-14	170	1,300	0.75
30.15	35,984	47,015	13	3	5	35.72	N/A	30.22	+0.025/-0.025	7/8-14	170	1,300	0.75
-	35,984	94,031	13	3	5	35.72	2.38	28.583	+0.005/-0.008	1 1/8-12	316	1,300	0.85
-	35,984	94,031	13	3	5	35.72	2.38	28.583	+0.005/-0.008	1 1/8-12	316	1,300	0.85
-	35,984	94,031	13	3	5	35.72	N/A	28.583	+0.005/-0.008	1 1/8-12	316	1,300	0.85
-	35,984	94,031	13	3	5	35.72	N/A	28.583	+0.005/-0.008	1 1/8-12	316	1,300	0.85

# Parameter sheet

## CF Inch roller series

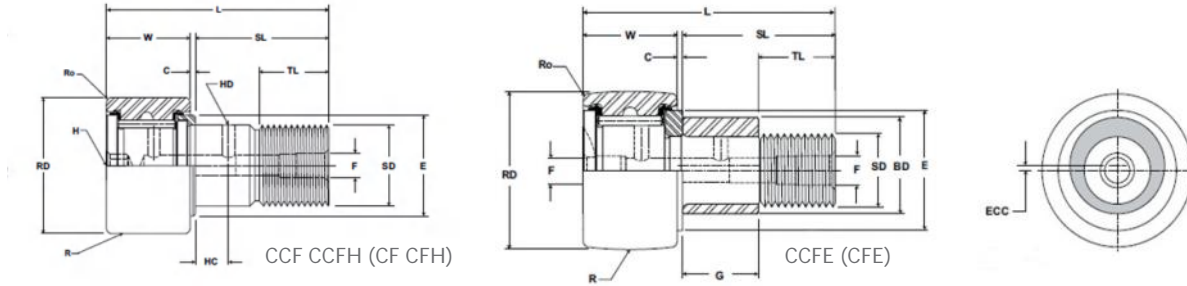

Bearing model		Structure dimension										Eccentric locking collar		
Sealless type	Seal type	RD	W		SD		SL	C	TL	L	R	ECC	G	
		mm	Nom	Tol	Nom	Tol	Nom	Tol	(Ref)	(Ref)	(Ref)	(Ref)	(Ref)	(Ref)
CF 2 1/2	CF 2 1/2 S	63.50	+0/-0.03	38.10	+0 / -0.13	25.40	+0.03/-0	57.2	0.8	28.57	96	-	-	-
CF 2 1/2 B	CF 2 1/2 SB	63.50	+0/-0.03	38.10	+0 / -0.13	25.40	+0.03/-0	57.2	0.8	28.57	96	-	-	-
CCF 2 1/2	CCF 2 1/2 S	63.50	+0/-0.03	38.10	+0 / -0.13	25.40	+0.03/-0	57.2	0.8	28.57	96	762	-	-
CCF 2 1/2 B	CCF 2 1/2 SB	63.50	+0/-0.03	38.10	+0 / -0.13	25.40	+0.03/-0	57.2	0.8	28.57	96	762	-	-
CFE 2 1/2	CFE 2 1/2 S	63.50	+0/-0.03	38.10	+0 / -0.13	25.40	+0.03/-0	57.2	0.8	28.57	96	-	0.76	28.58
CFE 2 1/2 B	CFE 2 1/2 SB	63.50	+0/-0.03	38.10	+0 / -0.13	25.40	+0.03/-0	57.2	0.8	28.57	96	-	0.76	28.58
CCFE 2 1/2	CCFE 2 1/2 S	63.50	+0/-0.03	38.10	+0 / -0.13	25.40	+0.03/-0	57.2	0.8	28.57	96	762	0.76	28.58
CCFE 2 1/2 B	CCFE 2 1/2 SB	63.50	+0/-0.03	38.10	+0 / -0.13	25.40	+0.03/-0	57.2	0.8	28.57	96	762	0.76	28.58
CFH 2 1/2	CFH 2 1/2 S	63.50	+0/-0.03	38.10	+0 / -0.13	31.75	+0.03/-0	57.2	0.8	28.57	96	-	-	-
CFH 2 1/2 B	CFH 2 1/2 SB	63.50	+0/-0.03	38.10	+0 / -0.13	31.75	+0.03/-0	57.2	0.8	28.57	96	-	-	-
CCFH 2 1/2	CCFH 2 1/2 S	63.50	+0/-0.03	38.10	+0 / -0.13	31.75	+0.03/-0	57.2	0.8	28.57	96	762	-	-
CCFH 2 1/2 B	CCFH 2 1/2 SB	63.50	+0/-0.03	38.10	+0 / -0.13	31.75	+0.03/-0	57.2	0.8	28.57	96	762	-	-
CF 2 3/4	CF 2 3/4 S	69.85	+0/-0.03	38.10	+0 / -0.13	25.40	+0.03/-0	57.2	0.8	28.57	96	-	-	-
CF 2 3/4 B	CF 2 3/4 SB	69.85	+0/-0.03	38.10	+0 / -0.13	25.40	+0.03/-0	57.2	0.8	28.57	96	-	-	-
CCF 2 3/4	CCF 2 3/4 S	69.85	+0/-0.03	38.10	+0 / -0.13	25.40	+0.03/-0	57.2	0.8	28.57	96	762	-	-
CCF 2 3/4 B	CCF 2 3/4 SB	69.85	+0/-0.03	38.10	+0 / -0.13	25.40	+0.03/-0	57.2	0.8	28.57	96	762	-	-
CFE 2 3/4	CFE 2 3/4 S	69.85	+0/-0.03	38.10	+0 / -0.13	25.40	+0.03/-0	57.2	0.8	28.57	96	-	0.76	28.58
CFE 2 3/4 B	CFE 2 3/4 SB	69.85	+0/-0.03	38.10	+0 / -0.13	25.40	+0.03/-0	57.2	0.8	28.57	96	-	0.76	28.58
CCFE 2 3/4	CCFE 2 3/4 S	69.85	+0/-0.03	38.10	+0 / -0.13	25.40	+0.03/-0	57.2	0.8	28.57	96	762	0.76	28.58
CCFE 2 3/4 B	CCFE 2 3/4 SB	69.85	+0/-0.03	38.10	+0 / -0.13	25.40	+0.03/-0	57.2	0.8	28.57	96	762	0.76	28.58
CFH 2 3/4	CFH 2 3/4 S	69.85	+0/-0.03	38.10	+0 / -0.13	31.75	+0.03/-0	57.2	0.8	28.57	96	-	-	-
CFH 2 3/4 B	CFH 2 3/4 SB	69.85	+0/-0.03	38.10	+0 / -0.13	31.75	+0.03/-0	57.2	0.8	28.57	96	-	-	-
CCFH 2 3/4	CCFH 2 3/4 S	69.85	+0/-0.03	38.10	+0 / -0.13	31.75	+0.03/-0	57.2	0.8	28.57	96	762	-	-
CCFH 2 3/4 B	CCFH 2 3/4 SB	69.85	+0/-0.03	38.10	+0 / -0.13	31.75	+0.03/-0	57.2	0.8	28.57	96	762	-	-

BD	Rated load		Mounting dimension						Thread	Tightening torque	Limit speed (grease)	Weight WT
	Cr	Cor	HC mm	HD	F	E	Ro	Seat hole diameter HBD				
±0.025 N			(Ref)	(Ref)	(Ref)	(Ref)	(Ref)	Nom Tol		Nm	RPM	kg
-	52,131	73,170	14	3	5	42.86	2.38	25.408 +0.005/-0.008	1-14	254	1,100	1.13
-	52,131	73,170	14	3	5	42.86	2.38	25.408 +0.005/-0.008	1-14	254	1,100	1.13
-	52,131	73,170	14	3	5	42.86	N/A	25.408 +0.005/-0.008	1-14	254	1,100	1.13
-	52,131	73,170	14	3	5	42.86	N/A	25.408 +0.005/-0.008	1-14	254	1,100	1.13
34.93	52,131	73,170	14	3	5	42.86	2.38	35.00 +0.025/-0.025	1-14	254	1,100	1.13
34.93	52,131	73,170	14	3	5	42.86	2.38	35.00 +0.025/-0.025	1-14	254	1,100	1.13
34.93	52,131	73,170	14	3	5	42.86	N/A	35.00 +0.025/-0.025	1-14	254	1,100	1.13
34.93	52,131	73,170	14	3	5	42.86	N/A	35.00 +0.025/-0.025	1-14	254	1,100	1.13
-	52,131	146,339	14	3	5	42.86	2.38	31.758 +0.005/-0.008	1 1/4-12	390	1,100	1.25
-	52,131	146,339	14	3	5	42.86	2.38	31.758 +0.005/-0.008	1 1/4-12	390	1,100	1.25
-	52,131	146,339	14	3	5	42.86	N/A	31.758 +0.005/-0.008	1 1/4-12	390	1,100	1.25
-	52,131	146,339	14	3	5	42.86	N/A	31.758 +0.005/-0.008	1 1/4-12	390	1,100	1.25
-	52,131	73,170	14	3	5	42.86	2.38	25.408 +0.005/-0.008	1-14	254	1,050	1.33
-	52,131	73,170	14	3	5	42.86	2.38	25.408 +0.005/-0.008	1-14	254	1,050	1.33
-	52,131	73,170	14	3	5	42.86	N/A	25.408 +0.005/-0.008	1-14	254	1,050	1.33
-	52,131	73,170	14	3	5	42.86	N/A	25.408 +0.005/-0.008	1-14	254	1,050	1.33
34.93	52,131	73,170	14	3	5	42.86	2.38	35.00 +0.025/-0.025	1-14	254	1,050	1.33
34.93	52,131	73,170	14	3	5	42.86	2.38	35.00 +0.025/-0.025	1-14	254	1,050	1.33
34.93	52,131	73,170	14	3	5	42.86	N/A	35.00 +0.025/-0.025	1-14	254	1,050	1.33
34.93	52,131	73,170	14	3	5	42.86	N/A	35.00 +0.025/-0.025	1-14	254	1,050	1.33
-	52,131	146,339	14	3	5	42.86	2.38	31.758 +0.005/-0.008	1 1/4-12	390	1,050	1.47
-	52,131	146,339	14	3	5	42.86	2.38	31.758 +0.005/-0.008	1 1/4-12	390	1,050	1.47
-	52,131	146,339	14	3	5	42.86	N/A	31.758 +0.005/-0.008	1 1/4-12	390	1,050	1.47
-	52,131	146,339	14	3	5	42.86	N/A	31.758 +0.005/-0.008	1 1/4-12	390	1,050	1.47

# Parameter sheet

## CF Inch roller series

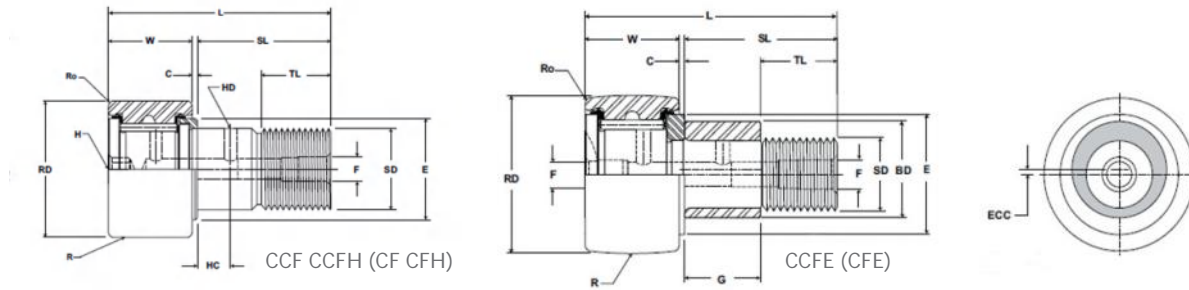

Bearing model		Structure dimension										Eccentric locking collar		
Sealless type	Seal type	RD mm		W		SD		SL	C	TL	L	R	ECC	G
		Nom	Tol	Nom	Tol	Nom	Tol	(Ref)	(Ref)	(Ref)	(Ref)	(Ref)	(Ref)	+0/-0.25
CF 3	CF 3 S	76.20	+0/-0.03	44.45	+0 / -0.13	31.75	+0.03/-0	63.5	0.8	31.75	108.7	-	-	-
CF 3 B	CF 3 SB	76.20	+0/-0.03	44.45	+0 / -0.13	31.75	+0.03/-0	63.5	0.8	31.75	108.7	-	-	-
CCF 3	CCF 3 S	76.20	+0/-0.03	44.45	+0 / -0.13	31.75	+0.03/-0	63.5	0.8	31.75	108.7	762	-	-
CCF 3 B	CCF 3 SB	76.20	+0/-0.03	44.45	+0 / -0.13	31.75	+0.03/-0	63.5	0.8	31.75	108.7	762	-	-
CFE 3	CFE 3 S	76.20	+0/-0.03	44.45	+0 / -0.13	31.75	+0.03/-0	63.5	0.8	31.75	108.7	-	0.52	31.75
CFE 3 B	CFE 3 SB	76.20	+0/-0.03	44.45	+0 / -0.13	31.75	+0.03/-0	63.5	0.8	31.75	108.7	-	0.52	31.75
CCFE 3	CCFE 3 S	76.20	+0/-0.03	44.45	+0 / -0.13	31.75	+0.03/-0	63.5	0.8	31.75	108.7	762	0.52	31.75
CCFE 3 B	CCFE 3 SB	76.20	+0/-0.03	44.45	+0 / -0.13	31.75	+0.03/-0	63.5	0.8	31.75	108.7	762	0.52	31.75
CFH 3	CFH 3 S	76.20	+0/-0.03	44.45	+0 / -0.13	38.10	+0.03/-0	63.5	0.8	31.75	108.7	-	-	-
CFH 3 B	CFH 3 SB	76.20	+0/-0.03	44.45	+0 / -0.13	38.10	+0.03/-0	63.5	0.8	31.75	108.7	-	-	-
CCFH 3	CCFH 3 S	76.20	+0/-0.03	44.45	+0 / -0.13	38.10	+0.03/-0	63.5	0.8	31.75	108.7	762	-	-
CCFH 3 B	CCFH 3 SB	76.20	+0/-0.03	44.45	+0 / -0.13	38.10	+0.03/-0	63.5	0.8	31.75	108.7	762	-	-
CF 3 1/4	CF 3 1/4 S	82.55	+0/-0.03	44.45	+0 / -0.13	31.75	+0.03/-0	63.5	0.8	31.75	108.7	-	-	-
CF 3 1/4 B	CF 3 1/4 SB	82.55	+0/-0.03	44.45	+0 / -0.13	31.75	+0.03/-0	63.5	0.8	31.75	108.7	-	-	-
CCF 3 1/4	CCF 3 1/4 S	82.55	+0/-0.03	44.45	+0 / -0.13	31.75	+0.03/-0	63.5	0.8	31.75	108.7	762	-	-
CCF 3 1/4 B	CCF 3 1/4 SB	82.55	+0/-0.03	44.45	+0 / -0.13	31.75	+0.03/-0	63.5	0.8	31.75	108.7	762	-	-
CFE 3 1/4	CFE 3 1/4 S	82.55	+0/-0.03	44.45	+0 / -0.13	31.75	+0.03/-0	63.5	0.8	31.75	108.7	-	0.52	31.75
CFE 3 1/4 B	CFE 3 1/4 SB	82.55	+0/-0.03	44.45	+0 / -0.13	31.75	+0.03/-0	63.5	0.8	31.75	108.7	-	0.52	31.75
CCFE 3 1/4	CCFE 3 1/4 S	82.55	+0/-0.03	44.45	+0 / -0.13	31.75	+0.03/-0	63.5	0.8	31.75	108.7	762	0.52	31.75
CCFE 3 1/4 B	CCFE 3 1/4 SB	82.55	+0/-0.03	44.45	+0 / -0.13	31.75	+0.03/-0	63.5	0.8	31.75	108.7	762	0.52	31.75
CFH 3 1/4	CFH 3 1/4 S	82.55	+0/-0.03	44.45	+0 / -0.13	38.10	+0.03/-0	63.5	0.8	31.75	108.7	-	-	-
CFH 3 1/4 B	CFH 3 1/4 SB	82.55	+0/-0.03	44.45	+0 / -0.13	38.10	+0.03/-0	63.5	0.8	31.75	108.7	-	-	-
CCFH 3 1/4	CCFH 3 1/4 S	82.55	+0/-0.03	44.45	+0 / -0.13	38.10	+0.03/-0	63.5	0.8	31.75	108.7	762	-	-
CCFH 3 1/4 B	CCFH 3 1/4 SB	82.55	+0/-0.03	44.45	+0 / -0.13	38.10	+0.03/-0	63.5	0.8	31.75	108.7	762	-	-

BD	Rated load		Mounting dimension						Thread	Tightening torque	Limit speed (grease)	Weight WT
	Cr	Cor	HC mm	HD	F	E	Ro	Seat hole diameter HBD				
	±0.025 N		(Ref)	(Ref)	(Ref)	(Ref)	(Ref)	Nom Tol		Nm	RPM	kg
-	69,923	110,800	16	3	6	53.98	3.18	31.758 +0.005/-0.008	1 1/4-12	390	950	1.91
-	69,923	110,800	16	3	6	53.98	3.18	31.758 +0.005/-0.008	1 1/4-12	390	950	1.91
-	69,923	110,800	16	3	6	53.98	N/A	31.758 +0.005/-0.008	1 1/4-12	390	950	1.91
-	69,923	110,800	16	3	6	53.98	N/A	31.758 +0.005/-0.008	1 1/4-12	390	950	1.91
44.45	69,923	110,800	16	3	6	53.98	3.18	44.52 +0.025/-0.025	1 1/4-12	390	950	1.91
44.45	69,923	110,800	16	3	6	53.98	3.18	44.52 +0.025/-0.025	1 1/4-12	390	950	1.91
44.45	69,923	110,800	16	3	6	53.98	N/A	44.52 +0.025/-0.025	1 1/4-12	390	950	1.91
44.45	69,923	110,800	16	3	6	53.98	N/A	44.52 +0.025/-0.025	1 1/4-12	390	950	1.91
-	69,923	221,599	16	3	6	53.98	3.18	38.108 +0.005/-0.008	1 1/2-12	565	950	2.07
-	69,923	221,599	16	3	6	53.98	3.18	38.108 +0.005/-0.008	1 1/2-12	565	950	2.07
-	69,923	221,599	16	3	6	53.98	N/A	38.108 +0.005/-0.008	1 1/2-12	565	950	2.07
-	69,923	221,599	16	3	6	53.98	N/A	38.108 +0.005/-0.008	1 1/2-12	565	950	2.07
-	69,923	110,800	16	3	6	53.98	3.18	31.758 +0.005/-0.008	1 1/4-12	390	880	2.18
-	69,923	110,800	16	3	6	53.98	3.18	31.758 +0.005/-0.008	1 1/4-12	390	880	2.18
-	69,923	110,800	16	3	6	53.98	N/A	31.758 +0.005/-0.008	1 1/4-12	390	880	2.18
-	69,923	110,800	16	3	6	53.98	N/A	31.758 +0.005/-0.008	1 1/4-12	390	880	2.18
44.45	69,923	110,800	16	3	6	53.98	3.18	44.52 +0.025/-0.025	1 1/4-12	390	880	2.18
44.45	69,923	110,800	16	3	6	53.98	3.18	44.52 +0.025/-0.025	1 1/4-12	390	880	2.18
44.45	69,923	110,800	16	3	6	53.98	N/A	44.52 +0.025/-0.025	1 1/4-12	390	880	2.18
44.45	69,923	110,800	16	3	6	53.98	N/A	44.52 +0.025/-0.025	1 1/4-12	390	880	2.18
-	69,923	221,599	16	3	6	53.98	3.18	38.108 +0.005/-0.008	1 1/2-12	565	880	2.35
-	69,923	221,599	16	3	6	53.98	3.18	38.108 +0.005/-0.008	1 1/2-12	565	880	2.35
-	69,923	221,599	16	3	6	53.98	N/A	38.108 +0.005/-0.008	1 1/2-12	565	880	2.35
-	69,923	221,599	16	3	6	53.98	N/A	38.108 +0.005/-0.008	1 1/2-12	565	880	2.35

# Parameter sheet

## CF Inch roller series

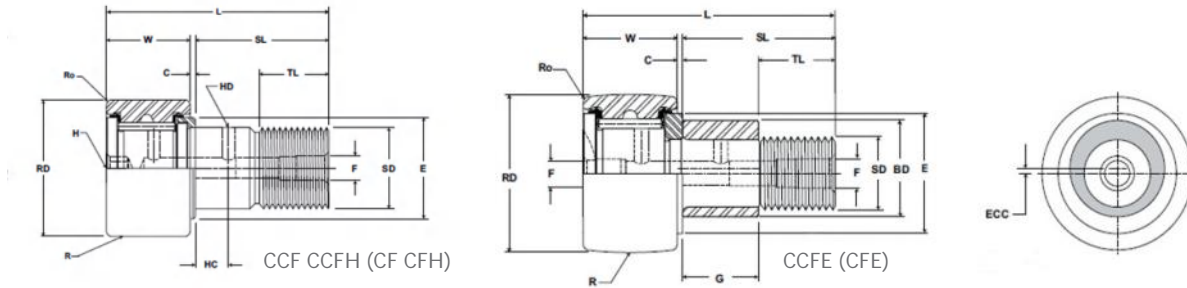

Bearing model		Structure dimension										Eccentric locking collar		
Sealless type	Seal type	RD	W		SD		SL	C	TL	L	R	ECC	G	
		mm	Nom	Tol	Nom	Tol	Nom	Tol	(Ref)	(Ref)	(Ref)	(Ref)	(Ref)	+0/-0.25
CF 3 1/2	CF 3 1/2 S	88.90	+0/-0.03	50.80	+0 / -0.13	34.93	+0.03/-0	69.9	0.8	34.93	121.4	-	-	-
CF 3 1/2 B	CF 3 1/2 SB	88.90	+0/-0.03	50.80	+0 / -0.13	34.93	+0.03/-0	69.9	0.8	34.93	121.4	-	-	-
CCF 3 1/2	CCF 3 1/2 S	88.90	+0/-0.03	50.80	+0 / -0.13	34.93	+0.03/-0	69.9	0.8	34.93	121.4	762	-	-
CCF 3 1/2 B	CCF 3 1/2 SB	88.90	+0/-0.03	50.80	+0 / -0.13	34.93	+0.03/-0	69.9	0.8	34.93	121.4	762	-	-
CFE 3 1/2	CFE 3 1/2 S	88.90	+0/-0.03	50.80	+0 / -0.13	34.93	+0.03/-0	69.9	0.8	34.93	121.4	-	0.52	34.93
CFE 3 1/2 B	CFE 3 1/2 SB	88.90	+0/-0.03	50.80	+0 / -0.13	34.93	+0.03/-0	69.9	0.8	34.93	121.4	-	0.52	34.93
CCFE 3 1/2	CCFE 3 1/2 S	88.90	+0/-0.03	50.80	+0 / -0.13	34.93	+0.03/-0	69.9	0.8	34.93	121.4	762	0.52	34.93
CCFE 3 1/2 B	CCFE 3 1/2 SB	88.90	+0/-0.03	50.80	+0 / -0.13	34.93	+0.03/-0	69.9	0.8	34.93	121.4	762	0.52	34.93
CFH 3 1/2	CFH 3 1/2 S	88.90	+0/-0.03	50.80	+0 / -0.13	44.45	+0.03/-0	69.9	0.8	34.93	121.4	-	-	-
CFH 3 1/2 B	CFH 3 1/2 SB	88.90	+0/-0.03	50.80	+0 / -0.13	44.45	+0.03/-0	69.9	0.8	34.93	121.4	-	-	-
CCFH 3 1/2	CCFH 3 1/2 S	88.90	+0/-0.03	50.80	+0 / -0.13	44.45	+0.03/-0	69.9	0.8	34.93	121.4	762	-	-
CCFH 3 1/2 B	CCFH 3 1/2 SB	88.90	+0/-0.03	50.80	+0 / -0.13	44.45	+0.03/-0	69.9	0.8	34.93	121.4	762	-	-
CF 4	CF 4 S	101.60	+0/-0.03	57.15	+0 / -0.13	38.10	+0.03/-0	88.9	0.8	38.1	146.8	-	-	-
CF 4 B	CF 4 SB	101.60	+0/-0.03	57.15	+0 / -0.13	38.10	+0.03/-0	88.9	0.8	38.1	146.8	-	-	-
CCF 4	CCF 4 S	101.60	+0/-0.03	57.15	+0 / -0.13	38.10	+0.03/-0	88.9	0.8	38.1	146.8	762	-	-
CCF 4 B	CCF 4 SB	101.60	+0/-0.03	57.15	+0 / -0.13	38.10	+0.03/-0	88.9	0.8	38.1	146.8	762	-	-
CFE 4	CFE 4 S	101.60	+0/-0.03	57.15	+0 / -0.13	38.10	+0.03/-0	88.9	0.8	38.1	146.8	-	0.52	50.80
CFE 4 B	CFE 4 SB	101.60	+0/-0.03	57.15	+0 / -0.13	38.10	+0.03/-0	88.9	0.8	38.1	146.8	-	0.52	50.80
CCFE 4	CCFE 4 S	101.60	+0/-0.03	57.15	+0 / -0.13	38.10	+0.03/-0	88.9	0.8	38.1	146.8	762	0.52	50.80
CCFE 4 B	CCFE 4 SB	101.60	+0/-0.03	57.15	+0 / -0.13	38.10	+0.03/-0	88.9	0.8	38.1	146.8	762	0.52	50.80
CFH 4	CFH 4 S	101.60	+0/-0.03	57.15	+0 / -0.13	50.80	+0.03/-0	88.9	0.8	38.1	146.8	-	-	-
CFH 4 B	CFH 4 SB	101.60	+0/-0.03	57.15	+0 / -0.13	50.80	+0.03/-0	88.9	0.8	38.1	146.8	-	-	-
CCFH 4	CCFH 4 S	101.60	+0/-0.03	57.15	+0 / -0.13	50.80	+0.03/-0	88.9	0.8	38.1	146.8	762	-	-
CCFH 4 B	CCFH 4 SB	101.60	+0/-0.03	57.15	+0 / -0.13	50.80	+0.03/-0	88.9	0.8	38.1	146.8	762	-	-

BD	Rated load		Mounting dimension						Thread	Tightening torque	Limit speed (grease)	Weight WT	
	Cr	Cor	HC mm	HD	F	E	Ro	Seat hole diameter HBD					
±0.025	N		(Ref)	(Ref)	(Ref)	(Ref)	(Ref)	Nom	Tol	Nm	RPM	kg	
-	101,414	140,668	17	3	6	61.91	3.18	34.933	+0.005/-0.008	1 3/8-12	475	820	2.91
-	101,414	140,668	17	3	6	61.91	3.18	34.933	+0.005/-0.008	1 3/8-12	475	820	2.91
-	101,414	140,668	17	3	6	61.91	N/A	34.933	+0.005/-0.008	1 3/8-12	475	820	2.91
-	101,414	140,668	17	3	6	61.91	N/A	34.933	+0.005/-0.008	1 3/8-12	475	820	2.91
46.02	101,414	140,668	17	3	6	61.91	3.18	46.10	+0.025/-0.025	1 3/8-12	475	820	2.91
46.02	101,414	140,668	17	3	6	61.91	3.18	46.10	+0.025/-0.025	1 3/8-12	475	820	2.91
46.02	101,414	140,668	17	3	6	61.91	N/A	46.10	+0.025/-0.025	1 3/8-12	475	820	2.91
46.02	101,414	140,668	17	3	6	61.91	N/A	46.10	+0.025/-0.025	1 3/8-12	475	820	2.91
-	101,414	281,336	17	3	6	61.91	3.18	44.458	+0.005/-0.008	1 3/4-12	565	820	3.18
-	101,414	281,336	17	3	6	61.91	3.18	44.458	+0.005/-0.008	1 3/4-12	565	820	3.18
-	101,414	281,336	17	3	6	61.91	N/A	44.458	+0.005/-0.008	1 3/4-12	565	820	3.18
-	101,414	281,336	17	3	6	61.91	N/A	44.458	+0.005/-0.008	1 3/4-12	565	820	3.18
-	101,414	199,137	19	3	6	71.04	3.18	38.108	+0.005/-0.008	1 1/2-12	565	700	4.29
-	101,414	199,137	19	3	6	71.04	3.18	38.108	+0.005/-0.008	1 1/2-12	565	700	4.29
-	101,414	199,137	19	3	6	71.04	N/A	38.108	+0.005/-0.008	1 1/2-12	565	700	4.29
-	101,414	199,137	19	3	6	71.04	N/A	38.108	+0.005/-0.008	1 1/2-12	565	700	4.29
50.80	101,414	199,137	19	3	6	71.04	3.18	50.85	+0.025/-0.025	1 1/2-12	565	700	4.29
50.80	101,414	199,137	19	3	6	71.04	3.18	50.85	+0.025/-0.025	1 1/2-12	565	700	4.29
50.80	101,414	199,137	19	3	6	71.04	N/A	50.85	+0.025/-0.025	1 1/2-12	565	700	4.29
50.80	101,414	199,137	19	3	6	71.04	N/A	50.85	+0.025/-0.025	1 1/2-12	565	700	4.29
-	133,373	398,274	19	3	6	71.04	3.18	50.808	+0.005/-0.008	2-12	565	700	4.91
-	133,373	398,274	19	3	6	71.04	3.18	50.808	+0.005/-0.008	2-12	565	700	4.91
-	133,373	398,274	19	3	6	71.04	N/A	50.808	+0.005/-0.008	2-12	565	700	4.91
-	133,373	398,274	19	3	6	71.04	N/A	50.808	+0.005/-0.008	2-12	565	700	4.91

# Parameter sheet

## CF Inch roller series

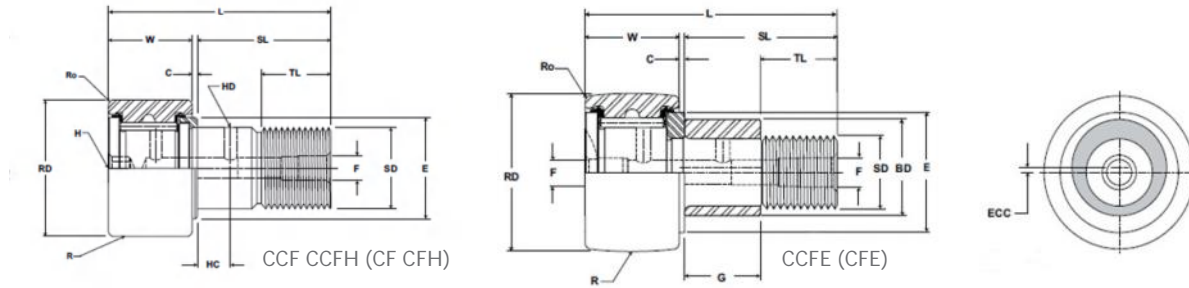

Bearing model		Structure dimension										Eccentric locking collar		
Sealless type	Seal type	RD mm		W		SD		SL	C	TL	L	R	ECC	G
		Nom	Tol	Nom	Tol	Nom	Tol	(Ref)	(Ref)	(Ref)	(Ref)	(Ref)	(Ref)	+0/-0.25
-	CF 5 SB	127	+0/-0.03	69.85	+0 / -0.13	50.8	+0.03/-0	128.6	1.57	65.1	200	-	-	-
-	CCF 5 SB	127	+0/-0.03	69.85	+0 / -0.13	50.8	+0.03/-0	128.6	1.57	65.1	200	1219	-	-
-	CFH 5 SB	127	+0/-0.03	69.85	+0 / -0.13	63.50	+0.03/-0	128.6	1.57	65.1	200	-	-	-
-	CCFH 5 SB	127	+0/-0.03	69.85	+0 / -0.13	63.50	+0.03/-0	128.6	1.57	65.1	200	1219	-	-
-	CF 6 SB	152.4	+0/-0.03	82.55	+0 / -0.13	63.50	+0.03/-0	152.4	1.57	76.2	236.5	-	-	-
-	CCF 6 SB	152.4	+0/-0.03	82.55	+0 / -0.13	63.50	+0.03/-0	152.4	1.57	76.2	236.5	1422	-	-
-	CFH 6 SB	152.4	+0/-0.03	82.55	+0 / -0.13	63.50	+0.03/-0	152.4	1.57	76.2	236.5	-	-	-
-	CCFH 6 SB	152.4	+0/-0.03	82.55	+0 / -0.13	63.50	+0.03/-0	152.4	1.57	76.2	236.5	1422	-	-
-	CF 7 SB	177.8	+0/-0.03	95.25	+0 / -0.13	76.2	+0.03/-0	195.3	1.57	104.77	292.1	-	-	-
-	CCF 7 SB	177.8	+0/-0.03	95.25	+0 / -0.13	76.2	+0.03/-0	195.3	1.57	104.77	292.1	1524	-	-
-	CFH 7 SB	177.8	+0/-0.03	95.25	+0 / -0.13	76.2	+0.03/-0	195.3	1.57	104.77	292.1	-	-	-
-	CCFH 7 SB	177.8	+0/-0.03	95.25	+0 / -0.13	76.2	+0.03/-0	195.3	1.57	104.77	292.1	1524	-	-
-	CF 8 SB	203.2	-	107.95	-	82.55	+0.03/-0	215.9	3.175	107.95	325.4	-	-	-
-	CCF 8 SB	203.2	-	107.95	-	82.55	+0.03/-0	215.9	3.175	107.95	325.4	1016	-	-
-	CF 9 SB	228.6	-	120.65	-	95.25	+0.03/-0	241.3	3.175	120.65	363.5	-	-	-
-	CCF 9 SB	228.6	-	120.65	-	95.25	+0.03/-0	241.3	3.175	120.65	363.5	1016	-	-
-	CF 10 SB	254	-	133.35	-	107.95	+0.03/-0	254	3.175	120.65	388.9	-	-	-
-	CCF 10 SB	254	-	133.35	-	107.95	+0.03/-0	254	3.175	120.65	388.9	1016	-	-

BD	Rated load		Mounting dimension							Thread	Tightening torque	Limit speed (grease)	Weight WT
	Cr	Cor	HC mm	HD	F	E	Ro	Seat hole diameter HBD					
	±0.025 N		(Ref)	(Ref)	(Ref)	(Ref)	(Ref)	Nom	Tol		Nm	RPM	kg
N/A	207,166	302,242	22	5	1/4" NPT	90.49	3.18	50.808	+0.005/-0.008	2-12	565	575	8.89
N/A	207,166	302,242	22	5	1/4" NPT	90.49	3.18	50.808	+0.005/-0.008	2-12	565	575	8.89
N/A	207,166	604,483	22	5	1/4" NPT	90.49	3.18	63.576	+0.005/-0.008	2 1/2-12	565	575	10.02
N/A	207,166	604,483	22	5	1/4" NPT	90.49	3.18	63.576	+0.005/-0.008	2 1/2-12	565	575	10.02
N/A	266,880	357,842	25	5	1/4" NPT	113.51	3.18	63.576	+0.005/-0.008	2 1/2-12	565	475	14.85
N/A	266,880	357,842	25	5	1/4" NPT	113.51	3.18	63.576	+0.005/-0.008	2 1/2-12	565	475	14.85
N/A	266,880	715,683	25	5	1/4" NPT	113.51	3.18	76.208	+0.005/-0.008	3-12	565	475	16.52
N/A	266,880	715,683	25	5	1/4" NPT	113.51	3.18	76.208	+0.005/-0.008	3-12	565	475	16.52
N/A	335,290	475,625	32	5	1/4" NPT	131.76	3.18	76.208	+0.005/-0.008	3-12	565	400	24.83
N/A	335,290	475,625	32	5	1/4" NPT	131.76	3.18	76.208	+0.005/-0.008	3-12	565	400	24.83
N/A	335,290	951,249	32	5	1/4" NPT	131.76	3.18	88.908	+0.005/-0.008	3 1/2-4	565	400	30.86
N/A	335,290	951,249	32	5	1/4" NPT	131.76	3.18	88.908	+0.005/-0.008	3 1/2-4	565	400	30.86
N/A	410,106	640,957	-	-	1/4" NPT	111.13	5.56	82.558	+0.005/-0.008	3 1/4-4	565	350	36.19
N/A	410,106	640,957	-	-	1/4" NPT	111.13	5.56	82.558	+0.005/-0.008	3 1/4-4	565	350	36.19
N/A	503,780	815,897	-	-	1/4" NPT	128.59	6.35	95.258	+0.005/-0.008	3 1/2-4	565	300	50.62
N/A	503,780	815,897	-	-	1/4" NPT	128.59	6.35	95.258	+0.005/-0.008	3 1/2-4	565	300	50.62
N/A	585,112	958,833	-	-	1/4" NPT	138.91	7.14	107.958	+0.005/-0.008	3 1/2-4	565	275	67.22
N/A	585,112	958,833	-	-	1/4" NPT	138.91	7.14	107.958	+0.005/-0.008	3 1/2-4	565	275	67.22

# Parameter sheet

Stud type track rollers with cylindrical roller

With axial guide

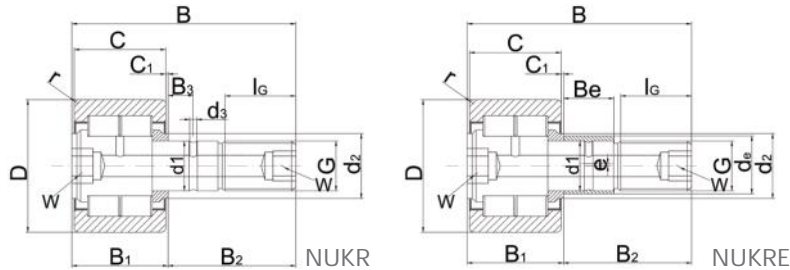

Model without eccentric locking collar	Mass	Model with eccentric locking collar	Mass	Dimension												
	g		g	D	d <sub>1</sub> h7	B	B <sub>1 max</sub>	B <sub>2</sub>	B <sub>3</sub>	C	C <sub>1</sub>	r <sub>min</sub>	d <sub>2</sub>	d <sub>3</sub>	G	
NUKR 35	164	-	-	35	16	52	19.6	32.5	7.8	18	0.8	0.6	20	3	M16X1.5	
-	-	NUKRE 35	177	35	16	52	22.6	29.5	-	18	3.8	0.6	27.6	-	M16X1.5	
PWKR 35 2RS	164	-	-	35	16	52	19.6	32.5	7.8	18	0.8	0.6	20	3	M16X1.5	
-	-	PWKRE 35 2RS	177	35	16	52	22.6	29.5	-	18	3.8	0.6	27.6	-	M16X1.5	
NUKR 40	242	-	-	40	18	58	21.6	36.5	8	20	0.8	1	22	3	M18X1.5	
-	-	NUKRE 40	258	40	18	58	24.6	33.5	-	20	3.8	1	30	-	M18X1.5	
PWKR 40 2RS	242	-	-	40	18	58	21.6	36.5	8	20	0.8	1	22	3	M18X1.5	
-	-	PWKRE 40 2RS	258	40	18	58	24.6	33.5	-	20	3.8	1	30	-	M18X1.5	
NUKR 47	380	NUKRE 47	400	47	20	66	25.6	40.5	9	24	0.8	1	27	4	M20X1.5	
PWKR 47 2RS	380	PWKRE 47 2RS	400	47	20	66	25.6	40.5	9	24	0.8	1	27	4	M20X1.5	
NUKR 52	450	NUKRE 52	470	52	20	66	25.6	40.5	9	24	0.8	1	31	4	M20X1.5	
PWKR 52 2RS	450	PWKRE 52 2RS	470	52	20	66	25.6	40.5	9	24	0.8	1	31	4	M20X1.5	
NUKR 62	795	NUKRE 62	824	62	24	80	30.6	49.5	11	28	1.3	1	38	4	M24X1.5	
PWKR 62 2RS	795	PWKRE 62 2RS	824	62	24	80	30.6	49.5	11	28	1.3	1	38	4	M24X1.5	
NUKR 72	1020	NUKRE 72	1050	72	24	80	30.6	49.5	11	28	1.3	1.1	44	4	M24X1.5	
PWKR 72 2RS	1020	PWKRE 72 2RS	1050	72	24	80	30.6	49.5	11	28	1.3	1.1	44	4	M24X1.5	
NUKR 80	1600	NUKRE 80	1670	80	30	100	37	63	15	35	1	1.1	47	4	M30X1.5	
PWKR 80 2RS	1600	PWKRE 80 2RS	1670	80	30	100	37	63	15	35	1	1.1	47	4	M30X1.5	
NUKR 90	1960	NUKRE 90	2 020	90	30	100	37	63	15	35	1	1.1	47	4	M30X1.5	
PWKR 90 2RS	1960	PWKRE 90 2RS	2 020	90	30	100	37	63	15	35	1	1.1	47	4	M30X1.5	

1) Press-fit lube nozzle to be separately packed for delivery Only supplied lube nozzle to be allowed

2) Nominal dimension of inner hexagonal hole Central lube adapter to the central lube system

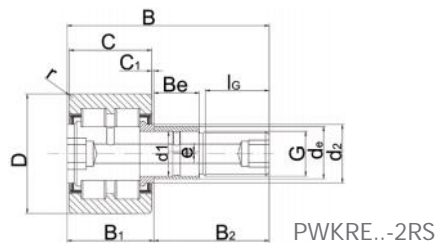
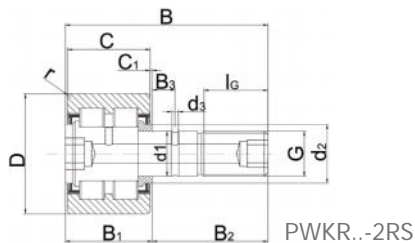

l <sub>G</sub>	W <sup>2)</sup>	Eccentric locking collar		Press-fit Lube nozzle <sup>1)</sup>	Tightening torque M <sub>A</sub> Nm	Basic rated load				Fatigue limit Load	Rotation speed n <sub>DC</sub> r/min	Model without eccentric locking collar	
		d <sub>e</sub>	h <sub>9</sub>			Dynamic load C <sub>rW</sub> N	Static load C <sub>0rW</sub> N	Dynamic load F <sub>r per</sub> N	Static load F <sub>0r per</sub> N				
17	8	-	-	-	NIPA2X7.5	58	15200	18600	8400	16500	2420	6500	NUKR 35
17	8	20	12	1	NIPA2X7.5	58	15200	18600	8400	16500	2420	6500	-
17	8	-	-	-	NIPA2X7.5	58	12500	14500	10500	14500	1750	6000	PWKR 35 2RS
17	8	20	12	1	NIPA2X7.5	58	12500	14500	10500	14500	1750	6000	-
19	8	-	-	-	NIPA2X7.5	87	18600	24800	12500	24800	3130	5500	NUKR 40
19	8	22	14	1	NIPA2X7.5	87	18600	24800	12500	24800	3130	5500	-
19	8	-	-	-	NIPA2X7.5	87	14200	17800	16000	17700	2150	5000	PWKR 40 2R5
19	8	22	14	1	NIPA2X7.5	87	14200	17800	16000	17700	2150	5000	-
21	10	24	18	1	NIPA2X7.5	120	28400	37400	15900	32300	4830	4200	NUKR 47
21	10	24	18	1	NIPA2X7.5	120	24300	30300	20500	32300	3720	3800	PWKR 47 2RS
21	10	24	18	1	NIPA2X7.5	120	28000	40200	17000	33500	5200	4200	NUKR 52
21	10	24	18	1	NIPA2X7.5	120	24500	32800	21500	32800	4050	3800	PWKR 52 2RS
25	14	28	22	1	NIPA3X9.5	220	39500	54000	23000	45800	7200	2600	NUKR 62
25	14	28	22	1	NIPA3X9.5	220	34800	45000	28000	45200	5700	2200	PWKR 62 2RS
25	14	28	22	1	NIPA3X9.5	220	44600	64000	31000	62000	8600	2600	NUKR 72
25	14	28	22	1	NIPA3X9.5	220	38400	53500	38000	53000	6800	2200	PWKR 72 2RS
32	14	35	29	1.5	NIPA3X9.5	450	68500	103000	47000	94500	14000	1800	NUKR 80
32	14	35	29	1.5	NIPA3X9.5	450	55800	78000	59000	78500	10400	1800	PWKR 80 2RS
32	14	35	29	1.5	NIPA3X9.5	450	77800	12000	75000	122000	16500	1800	NUKR 90
32	14	35	29	1.5	NIPA3X9.5	450	61500	91000	91000	91000	12000	1800	PWKR 90 2RS

# Parameter sheet

Ball bearing track rollers  
Single-row seal

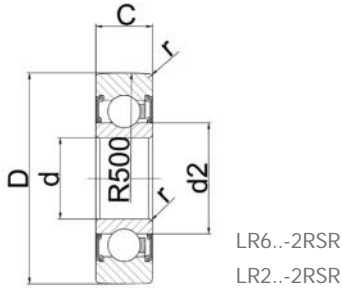

Model	Mass	Dimension					Basic rated load		Fatigue limit Load	Rotation speed $n_{DG}$ r/min
		D	d	C	$d_2$	$r_{min}$	Dynamic load $C_{rw}$ N	Static load $C_{0rw}$ N		
	g	D	d	C	$d_2$	$r_{min}$	$C_{rw}$ N	$C_{0rw}$ N	$C_{urw}$ N	$n_{DG}$ r/min
LR 604 2RSR	10	13	4	4	6.1	0.2	860	350	18	23000
LR 605 2RSR	10	16	5	5	7.5	0.2	1200	500	25.4	22500
LR 606 2RSR	10	19	6	6	8.7	0.3	1840	780	39.3	22000
LR 607 2RSR	10	22	7	6	9	0.3	2100	870	42.2	19500
LR 608 2RSR	20	24	8	7	10	0.3	2750	1220	62.5	18500
LR 6000 2RSR	20	28	10	8	14.6	0.3	4500	2450	126	15500
LR 6001 2RSR	30	30	12	8	16.6	0.3	4700	2750	142	14500
LR 200 2RS	50	32	10	9	16.6	0.6	4850	2300	116	12500
LR 200 X 2RS <sup>1)</sup>	50	32	10	9	16.6	0.6	4850	2300	116	12500
LR 201 2RSR	50	35	12	10	18.3	0.6	5600	2750	136	11500
LR 201 X 2RSR <sup>1)</sup>	50	35	12	10	18.3	0.6	5600	2750	136	11500
LR 202 2RSR	70	40	15	11	21	0.6	6500	3300	168	10500
LR 202 X 2RSR <sup>1)</sup>	70	40	15	11	21	0.6	6500	3300	168	10500
LR 203 2RSR	110	47	17	12	24	0.6	8400	4420	220	8500
LR 203 X 2RSR <sup>1)</sup>	110	47	17	12	24	0.6	8400	4420	220	8500
LR 204 2RSR	150	52	20	14	29	1	10500	5600	290	8000
LR 204 X 2RSR <sup>1)</sup>	150	52	20	14	29	1	10500	5600	290	8000
LR 205 2RSR	230	62	25	15	33.5	1	12300	7050	358	7000
LR 205 X 2RSR <sup>1)</sup>	230	62	25	15	33.5	1	12300	7050	358	7000
LR 206 2RS	330	72	30	16	37.4	1	16500	9600	490	5500
LR 206 X 2RS <sup>1)</sup>	330	72	30	16	37.4	1	16500	9600	490	5500
LR 207 2RS	400	80	35	17	42.4	1.1	20300	12000	630	4500
LR 207 X 2RS <sup>1)</sup>	400	80	35	17	42.4	1.1	20300	12000	630	4500
LR 209 2RS	500	90	45	19	53.2	1.1	22200	13600	720	3600
LR 209 X 2RS <sup>1)</sup>	500	90	45	19	53.2	1.1	22200	13600	720	3600

1) Cylindrical outer surface idler wheel  
Bearing with radius of curvature R=500mm and clearance seal

## Ball bearing track rollers

Dual-row seal

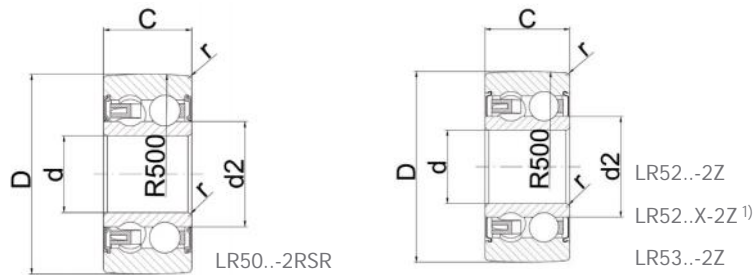

Model	Mass	Dimension					Basic rated load		Fatigue limit	Rotation speed
		D	d	C	d <sub>2</sub>	r <sub>min</sub>	Dynamic load C <sub>rw</sub> N	Static load C <sub>0rw</sub> N	Load C <sub>urw</sub> N	n <sub>DG</sub> r/min
LR 50/5 2RSR	10	17	5	7	8.2	0.2	1680	940	48.4	11500
LR 50/6 2R5R	20	19	6	9	9.3	0.3	2700	1360	66	10500
LR 50/7 2R5R	20	22	7	10	10.5	0.3	3200	1680	80	9800
LR 50/8 2RSR <sup>2)</sup>	30	24	8	11	10.5	0.3	4250	2380	118	9800
LR 5000 2RS	30	28	10	12	13.5	0.3	4700	2800	144	9000
LR 5001 2RS	30	30	12	12	15.5	0.3	5100	3100	160	8500
LR 5200 2Z	70	32	10	14	15.4	0.6	6750	4100	206	10500
LR 5200 X 2Z <sup>1)</sup>	70	32	10	14	15.4	0.6	6750	4100	206	10500
LR 5200 2RS	70	32	10	14	15.4	0.6	6750	4100	206	8000
LR 5002 2RS	50	35	15	13	20.4	3	6500	4150	215	7000
LR 5201 2Z	80	35	12	15.9	17.1	0.6	8600	5150	260	9800
LR 5201 X 2Z <sup>1)</sup>	80	35	12	15.9	17.1	0.6	8600	5150	260	9800
LR 5201 2RS	80	35	12	15.9	17.1	0.6	8600	5150	260	7500
LR 5003 2RS	70	40	17	14	21.6	3	7800	5200	268	6000
LR 5202 2Z	110	40	15	15.9	20	0.6	9800	6200	318	9800
LR 5202 X 2Z <sup>1)</sup>	110	40	15	15.9	20	0.6	9800	6200	318	9800
LR 5202 2RS	110	40	15	15.9	20	0.6	9800	6200	318	7000

# Parameter sheet

Ball bearing track rollers

Dual-row seal

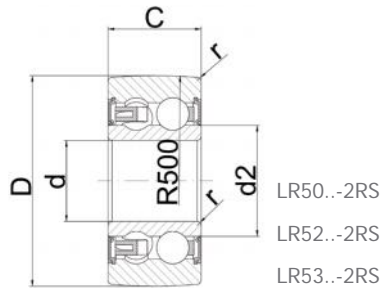

Model	Mass	Dimension					Basic rated load		Fatigue limit	Rotation speed
		D	d	C	d <sub>2</sub>	r <sub>min</sub>	Dynamic load C <sub>rw</sub> N	Static load C <sub>0rw</sub> N	Load C <sub>urw</sub> N	n <sub>DG</sub> r/min
LR 5004 2RS	120	47	20	16	25.2	0.6	11600	7600	390	5400
LR 5203 2Z	170	47	17	17.5	22.5	0.6	12600	8300	410	7400
LR 5203 X 2Z <sup>1)</sup>	170	47	17	17.5	22.5	0.6	12600	8300	410	7400
LR 5203 2RS	170	47	17	17.5	22.5	0.6	12600	8300	410	5400
LR 5005 2RS	150	52	25	16	29.8	0.6	11500	8100	430	4600
LR 5204 2Z	230	52	20	20.6	26.5	1	16000	10600	540	7000
LR 5204 X 2Z <sup>1)</sup>	230	52	20	20.6	26.5	1	16000	10600	540	7000
LR 5204 2RS	230	52	20	20.6	26.5	1	16000	10600	540	5000
LR 5303 2RS	210	52	17	22.2	23.5	1	17400	11200	550	4700
LR 5006 2RS	250	62	30	19	35.5	1	16000	11800	620	4000
LR 5205 2Z	340	62	25	20.6	30.3	1	18600	13000	660	6400
LR 5205 X 2Z <sup>1)</sup>	340	62	25	20.6	30.3	1	18600	13000	660	6400
LR 5205 2RS	340	62	25	20.6	30.3	1	18600	13000	660	4500
LR 5304 2Z	340	62	20	22.2	29	1.1	21400	14600	730	6400
LR 5304 2RS	340	62	20	22.2	29	1.1	21400	14600	730	4500
LR 5007 2RS	300	68	35	20	41.7	1	17600	13000	710	4300

1) Cylindrical outer surface idler wheel  
Bearing with radius of curvature R=500mm and clearance seal

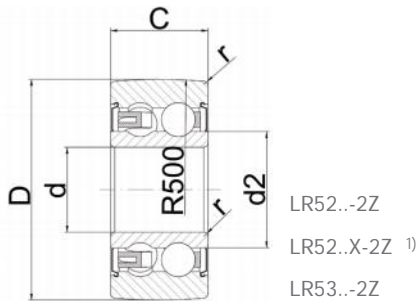

Model	Mass	Dimension					Basic rated load			Fatigue limit	Rotation speed
		D	d	C	d <sub>2</sub>	r <sub>min</sub>	Dynamic load	Static load	F <sub>r per</sub>		
	g	D	d	C	d <sub>2</sub>	r <sub>min</sub>	C <sub>rw</sub> N	C <sub>0rw</sub> N	F <sub>r per</sub> N	C <sub>urw</sub> N	n <sub>DG</sub> r/min
LR 5206 2Z	510	72	30	23.8	37.4	1	24500	17500	-	920	4800
LR 5206 X 2Z <sup>1)</sup>	510	72	30	23.8	37.4	1	24500	17500	-	920	4800
LR 5206 2RS	510	72	30	23.8	37.4	1	24500	17500	-	920	3500
LR 5305 2Z	500	72	25	25.4	34.4	1.1	27000	19500	-	980	5500
LR 5305 2RS	500	72	25	25.4	34.4	1.1	27000	19500	-	980	3800
LR 5207 2Z	660	80	35	27	42.4	1.1	30000	22000	-	1150	3800
LR 5207 X 2Z <sup>1)</sup>	660	80	35	27	42.4	1.1	30000	22000	-	1150	3800
LR 5207 2RS	660	80	35	27	42.4	1.1	30000	22000	-	1150	2800
LR 5306 2Z	670	80	30	30.2	41.4	1.1	35000	25000	-	1300	4100
LR 5306 2RS	670	80	30	30.2	41.4	1.1	35000	25000	-	1300	3100
LR 5208 2Z	750	85	40	30.2	48.4	1.1	34800	25500	21000	1350	3500
LR 5208 X 2Z <sup>1)</sup>	750	85	40	30.2	48.4	1.1	34800	25500	21000	1350	3500
LR 5208 2RS	750	85	40	30.2	48.4	1.1	34800	25500	21000	1350	2500
LR 5307 2Z	970	90	35	34.9	47.7	1.5	43000	32000	-	1650	3600
LR 5307 2RS	970	90	35	34.9	47.7	1.5	43000	32000	-	1650	2500
LR 5308 2Z	1200	100	40	36.5	52.4	1.5	53000	40000	-	2050	3300
LR 5308 2RS	1200	100	40	36.5	52.4	1.5	53000	40000	-	2050	2300

# Parameter sheet

Standard combined bearings (4.053 - 4.063)

Precision combined bearings PR (4.054 - 4.063)

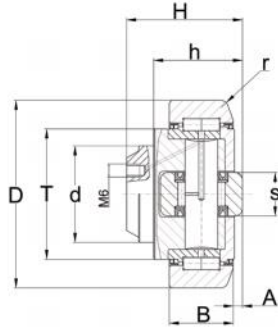
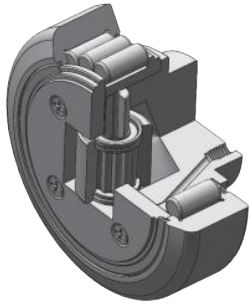

Model	Dimension (mm)							Load (KN)							Weight	
	D	H	h	d	T	B	A	S	r	Fr	Fa	C <sub>r</sub>	C <sub>or</sub>	C <sub>a</sub>	C <sub>oa</sub>	kg
4.053	52.5	33	27	30	40	17	5	15	2	5.23	1.68	24	32	7	7	0.46
4.054	62.5	37.5	30.5	30	42	20	2.5	20	3	10.3	3.2	31	35.5	11	11	0.53
PR4.054	64.8	37.5	30.5	30	42	20	2.5	20	3	10.3	3.2	31	35.5	11	11	0.55
4.055	70.1	44	36	35	48	23	2.5	22	4	12.4	3.87	45.5	51	13	14	0.8
PR4.055	73.8	44	36	35	48	23	2.5	22	4	12.4	3.87	45.5	51	13	14	0.85
4.056	77.7	48	36.5	40	54	23	3	26	4	12.9	4	48	56.8	18	18	1
PR4.056	81.8	48	36.5	40	54	23	3	26	4	12.9	4	48	56.8	18	18	1.1
4.057	77.7	40	29	40	53	23	3	26	4	12.9	4	48	56.8	18	18	0.87
4.058	88.4	57	44	45	59	30	3.5	26	3	22.4	7	68	72	23	23	1.62
PR4.058	92.8	57	44	45	59	30	3.5	26	3	22.4	7	68	72	23	23	1.7
4.059	101.2	46	33	50	67	28	3	30	3	22	7	72	83	26	27	1.74
4.060	107.7	54	39	55	71	31	3	34	5	23.8	7.44	81	95	31	36	2.27
4.061	107.7	69	55	60	71	31	4	34	5	23.8	7.44	81	95	31	36	2.82
PR4.061	111.8	69	55	60	71	31	4	34	5	23.8	7.44	81	95	31	36	2.95
4.062	123	72.3	56	60	80	37	5	40	5	33.9	10.6	110	132	43	50	3.89
PR4.062	127.8	72.3	56	60	80	37	5	40	5	33.9	10.6	110	132	43	50	4.1
4.063	149	77.5	58.5	60	103	45	5.5	50	3	59.2	18.5	151	192	68	71	6.52
PR4.063	153.8	77.5	58.5	60	103	45	5.5	50	3	59.2	18.5	151	192	68	71	6.85

Standard combined bearings of adjustable shim type (4.072 - 4.080)

Precision combined bearings KCP of adjustable shim type PR (4.072 - 4.080)

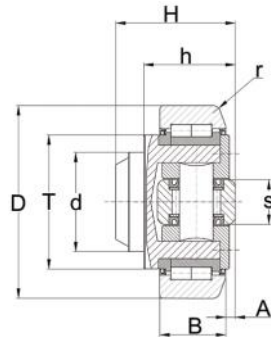
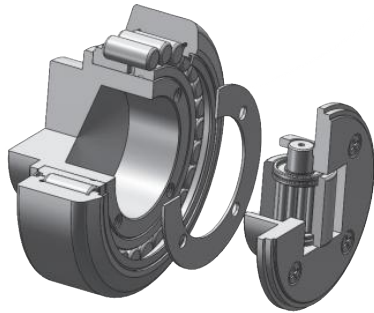

Model	Dimension			Load (KN)										Weight		
	D	H	h	d	T	B	A	S	r	Fr	Fa	C <sub>r</sub>	C <sub>or</sub>	C <sub>a</sub>	C <sub>oa</sub>	kg
4.072	62.5	43	33	30	42	20	5.5	16	3	10.3	3.2	31	35.5	8	8	0.56
PR4.072	64.8	43	33	30	42	20	5.5	16	3	10.3	3.2	31	35.5	8	8	0.56
4.073	70.1	48	40	35	48	23	6.5	16	4	12.5	3.9	46	53	15	14	0.85
PR4.073	73.8	48	40	35	48	23	6.5	16	4	12.5	3.9	46	53	15	14	0.85
4.074	78.1	50.5	39.5	40	54	23	7	21	4	13	4.2	49	57	15	14	1.02
PR4.07	81.8	50.5	39.5	40	54	23	7	21	4	13	4.2	49	57	15	14	1.02
4.075	77.7	45	34	40	54	23	7	21	4	13	4.2	49	57	15	14	0.92
4.076	88.4	61	48	45	59	30	7	21	3	22.5	7.2	69	73	15	15	1.69
PR4.076	92.8	61	48	45	59	30	7	21	3	22.5	7.2	69	73	15	15	1.69
4.077	101.2	50.5	37.5	50	67	28	7	21	3	22.3	7.2	73	82	18	19	1.85
4.078	107.7	58.5	44.5	55	71	31	8	33	5	24	7.6	82	96	32	36	2.38
4.0784	107.7	69	55	60	71	31	8	33	5	24	7.6	82	96	32	36	2.8
PR4.0784	111.8	69	55	60	71	31	8	33	5	24	7.6	82	96	32	36	2.8
4.079	123	75.5	59.5	60	80	37	8	33	5	34	10.6	112	133	35	38	4.08
PR4.079	127.8	75.5	59.5	60	80	37	8	33	5	34	10.6	112	133	35	38	4.08
4.080	149	89	69	60	103	45	15	50	5	39.6	19	152	193	69	72	6.7
PR4.080	153.8	89	69	60	103	45	15	50	5	39.6	19	152	193	69	72	6.7

## Parameter sheet

Standard combined bearings of axially adjustable type (eccentric tooth pivot) (4.454 - 4.463)

Precision combined bearings of adjustable shim type (eccentric tooth pivot) PR (4.454 - 4.463)

Standard combined bearings of axially adjustable type (eccentric hexagonal cabinet shaft) (4.085 - 4.094)

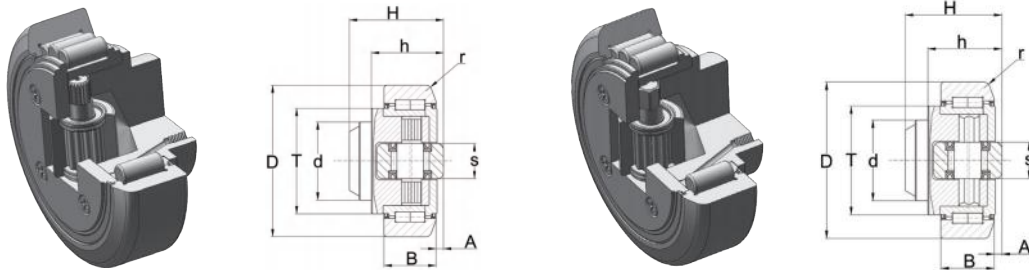

Dimension

Model

Model	D	H	h	d	T	B	A	S	r
4.454	62.5	37.5-39	30.5-32	30	42	20	4-5.5	20	3
PR4.454	64.8	37.5-39	30.5-32	30	42	20	4-5.5	20	3
4.455	70.1	44-45.5	36-37.5	35	48	23	4-5.5	20	4
PR4.455	73.8	44-45.5	36-37.5	35	48	23	4-5.5	20	4
4.456	77.7	48-49.5	37-38.5	40	54	23	3.5-5	26	4
PR4.456	81.8	48-49.5	37-38.5	40	54	23	3.5-5	26	4
4.457	77.7	40-41.5	29-30.5	40	54	23	3.5-5	26	4
4.458	88.4	57-58.5	44-45.5	45	59	30	4-5.5	26	4
PR4.458	92.8	57-58.5	44-45.5	45	59	30	4-5.5	26	4
4.459	101.6	46-48	33-35	50	69	26	4.5-6.5	30	3
4.460	108.5	54-56	40-42	55	69	31	4-6	30	5
4.461	107.7	69-71	55-57	60	69	31	4-6	30	5
PR4.461	111.8	69-71	55-57	60	69	31	4-6	30	5
4.462	123	72.3-76.3	56-60	60	80	37	5-9	34	5
PR4.462	127.8	72.3-76.3	56-60	60	80	37	5-9	34	5
4.463	149.4	78.5-82.5	58.5-62.5	60	108	45	6-10	34	3
PR4.463	153.8	78.5-82.5	58.5-62.5	60	108	45	6-10	34	3
PR4.085	184.8	95.7-98.7	76.3-79.3	100	124	57.3	6.5-9.5	60	3
4.085	180	95.7-98.7	76.3-79.3	100	124	57.3	6.5-9.5	60	-
4.089	165	69-72	53-56	80	113	40	5-8	50	-
4.090	190	84.5-87.5	64.5-67.5	100	124	48	6.5-9.5	60	-
4.091	220	94.5-97.5	74.5-77.5	110	146	58	6.5-9.5	75	-
4.092	250	102-105	77-80	120	168	60	7-10	75	-
4.093	280	119.5-123.5	89.5-93.5	150	188	72	7.5-11.5	90	-
4.094	320	135-139	110-114	150	218	85	10-14	90	-

Load (KN)						Weight	
Fr	Fa	C <sub>r</sub>	C <sub>or</sub>	C <sub>a</sub>	C <sub>oa</sub>	kg	Model
10.2	3.3	31	36	11	11	0.53	4.454
10.2	3.3	31	36	11	11	0.55	PR4.454
12.5	3.9	46	53	14	14	0.8	4.455
12.5	3.9	46	53	14	14	0.82	PR4.455
13	4.2	49	57	19	18	1	4.456
13	4.2	49	57	19	18	1.05	PR4.456
13	4.2	49	57	19	18	0.87	4.457
22.5	7.2	68	73	24	23	1.62	4.458
22.5	7.2	68	73	24	23	1.65	PR4.458
22	7.2	72	83	26	28	1.74	4.459
24	7.4	82	96	32	36	2.27	4.460
24	7.4	82	96	32	36	2.82	4.461
24	7.4	82	96	32	36	2.85	PR4.461
34	10.6	112	133	44	50	3.6	4.462
34	10.6	112	133	44	50	4	PR4.462
59	19	152	193	69	72	6.3	4.463
59	19	152	193	69	72	6.7	PR4.463
91.5	23.5	207	243	73	83	12.5	PR4.085
91.5	23.5	207	243	73	83	11.5	4.085
41.5	13.9	210	385	85	130	9.2	4.089
58	19.3	265	498	100	178	10.6	4.090
83	29	326	680	138	256	17.3	4.091
102	33.8	368	748	138	256	23.9	4.092
139	46	488	1065	180	485	36	4.093
192	57.5	540	1370	208	420	50	4.094

# Parameter sheet

Standard combined bearings with coupling screw hole KB (4.072 - 4.080)

Precision combined bearings with coupling screw hole KBPR (4.072 - 4.080)

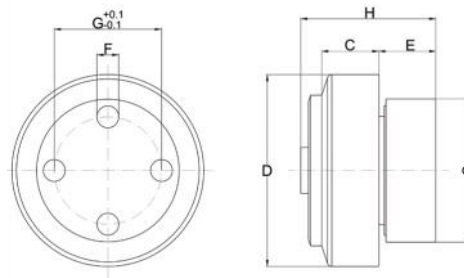
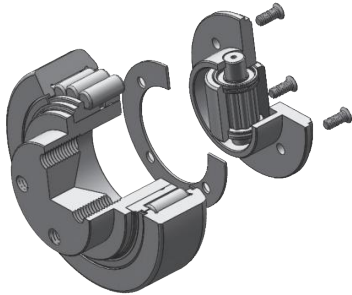

Model	Dimension										Weight				
	D	H	d	C	E	F	G	Fr	Fa	C	C <sub>o</sub>	C <sub>a</sub>	C <sub>oa</sub>	kg	
KB4.072	62.5	43	50	20	17.5	M10X13	30	10.2	3.3	31	36	8	8	0.65	
KBPR4.072	64.8	43	50	20	17.5	M10X13	30	10.2	3.3	31	36	8	8	0.68	
KB4.073	70.1	55	60	23	25.5	M12X18	40	12.5	3.9	46	53	15	14	1.1	
KBPR4.073	73.8	55	60	23	25.5	M12X18	40	12.5	3.9	46	53	15	14	1.15	
KB4.074	78.1	54.5	60	23	24.5	M12X18	40	13	4.2	49	57	15	14	1.2	
KBPR4.074	81.8	54.5	60	23	24.5	M12X18	40	13	4.2	49	57	15	14	1.3	
KB4.076	88.4	68	70	30	31	M14X20	44	22.5	7.2	69	73	15	15	2.05	
KBPR4.076	92.8	68	70	30	31	M14X20	44	22.5	7.2	68	73	15	15	2.13	
KB4.0784	107.7	75	80	31	36	M14X22	54	24	7.4	82	96	32	36	3.2	
KBPR4.0784	111.8	75	80	31	36	M14X22	54	24	7.4	82	96	32	36	3.34	
KB4.079	123	79.2	100	37	34.2	M16X23	60	34	10.6	112	133	35	38	4.9	
KBPR4.079	127.8	79.2	100	37	34.2	M16X23	60	34	10.6	112	133	35	38	5.1	
KB4.080	149	89	120	45	29	M16X23	80	39.6	19	152	193	69	72	8	
KBPR4.080	153.8	89	120	45	29	M16X23	80	39.6	19	152	193	69	72	8.3	

Standard radial roller bearing (2.054 - 2.063)

Precision radial roller bearing PR (2.054 - 2.063)

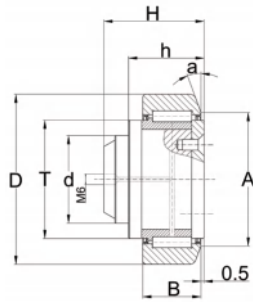
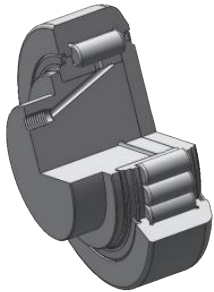

Model	Dimension									Weight		
	D	H	h	d	T	B	A	a	Fr	C <sub>r</sub>	C <sub>or</sub>	kg
2.054	62.5	34.5	26.5	30	42	20	50	20°	10.2	31	36	0.55
PR2.054	64.8	34.5	26.5	30	42	20	50	20°	10.2	31	36	0.56
2.055	70.1	42	34	35	48	23	57	20°	12.5	46	53	0.8
PR2.055	73.8	42	34	35	48	23	57	20°	12.5	46	53	0.82
2.056	77.7	45.5	34	40	53	23	61	20°	13	49	57	1.05
PR2.056	81.8	45.5	34	40	53	23	61	20°	13	49	57	1.07
2.058	88.4	54	41	45	59	30	68	20°	22.5	69	73	1.7
PR2.058	92.8	54	41	45	59	30	68	20°	22.5	69	73	1.73
2.061	107.7	65.5	51.5	60	71	31	82	20°	24	82	96	2.9
PR2.061	111.8	65.5	51.5	60	71	31	82	20°	24	82	96	2.92
2.062	123	67.8	51.5	60	80	37	92	20°	34	112	133	4
PR2.062	127.8	67.8	51.5	60	80	37	92	20°	34	112	133	4.22
2.063	149	74	54	60	103	45	116	15°	59	152	193	6.7
PR2.063	153.8	74	54	60	103	45	116	15°	59	152	193	6.75





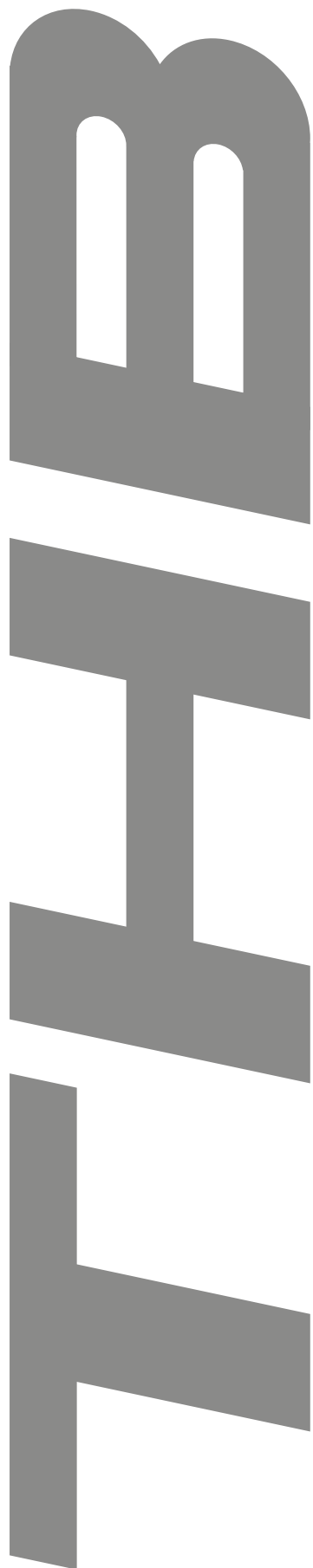

**Make Transmission More Free**

THB BEARINGS CO.,LTD

Web:[www.thb-bearings.com](http://www.thb-bearings.com)

Email:[info@thb-bearings.com](mailto:info@thb-bearings.com)

Tel: +86(0)21 5484 6037

Address: 601, Building 2, No.525, Yuanjiang Road,  
Minhang District, Shanghai, 200241, China.

T202305